



BINDERY KNIVES & PARTS



FOLDER PARTS



QUALITY PARTS

SERVICE

PERSONALISED



FINISHING

**Authorised
Distributor for:**

Schönenberger WIDIA



Tech ni Fold

DeLUXE STITCHER
COMPANY INC.

hohner

Product Range

- Parts for Folding Machines
- Stitching Heads & Parts
- Stitching Machines
- Guillotine Knives
- 3 Knife Trimmer Knives
- Cutting Accessories
- Milling Heads and Tools
- Parts for Saddlestitchers
- Drill Bits
- Suction Cups & Discs
- Brushes



Christian Birk
cbirk@birk-blyme.com

Jan Blyme
jblyme@birk-blyme.com



Patrick Day
pday@birk-blyme.com

Leeharne Hawley
lhawley@birk-blyme.com



Since 1988 Birk & Blyme have been dedicated to the supply of premium quality consumables, specialised service and reliable support to the Printing and Print Finishing Industry.

Our operation carries a comprehensive range of knives and bindery components, sourced from only leading manufacturers worldwide.

Compare our quality and price for VALUE!

We look forward to servicing your future Spare Parts requirements.

Christian Birk & Jan Blyme



Perumal Naidu

Our New Team Member

Malaysia & Singapore

Printech Industrial Supply

10 Jalan Denai 8
Taman Bukit Jaya
Ulu Tiram 81800
Johor Bahru, Johor, Malaysia

Ph: +60 7 861 2733

Fax: +60 7 861 4470

Email: peru_pis@streamyx.com

FOLDING

4-6	Perfs, Slitters & Scoring Blades
7	Transport Collars, Anvils & Blade Holders
8	Trim Kits
9	Spacers, Trim Rings & Pull-Out Tyres
10-11	Perforation & Trim Strippers
12	Tri-Creaser
13	Micro Perf & CP Applicator
14	Multi-Tool
15	Fold Rollers
16	Segmented Glue Rollers & Glue Nose
17	Stahl* & MBO* Drive belts
18	Cross Carrier Sheet Guide, Drive & Split Belts
19	Feeder Parts, Marble Carriers & Side Guides
20	Sheet Hold-Down, Marbles & Marble Cups
21	Stahl* Feeder Parts
22	Register Board Belts, Pulleys/Air Blowers
23	Deflectors, Drive Shafts, Variable Speed Pulleys
24	Clamping Levers, Dust Seals, Plate Bearing Brackets
25	Gears, Springs & Stahl* Style Gate Fold Parts
26	MBO* & Stahl* Style Fold Plate Parts
27	Bearings, MBO* Style Drive Belts & Handwheels
28	Stub & Slitter hafts, MBO* Style Support Pins
29	Stahl* Style Stacker Parts - VSA Parts

STITCHING

30-31	Deluxe Stitcher Machines & Heads
32-33	Hohner Stitcher Machines & Heads
34-36	Stitcher Head Parts
37-38	Saddlestitcher Parts

BRUSHES

39	Brushes
----	---------

SUCKERS

40-41	Suction Cups
-------	--------------

CUTTING

42-43	Paper Cutting Knives
44-45	Cutting Accessories
46-47	Rotary Trimmers & Milling Tools

DRILLING

48-49	Paper Drills
50	Drill Heads, Drill Sharpeners



- At BIRK & BLYME we offer a
- A WIDE RANGE OF QUALITY PRODUCTS
 - FAST DELIVERY SERVICE
 - MONEY BACK GUARANTEE
 - HELPFUL FRIENDLY SERVICE

30 day accounts to approved applicants

OUR GUARANTEE

We guarantee the quality of our product, we will replace faulty product or your money back. Claims on faulty or damaged product must be lodged within 14 days of receipt of goods.

You can ORDER by
PHONE: +61 2 9948 6822
FAX: +61 2 9948 6944
Email: info@birk-blyme.com
On-Line: www.order.birk-blyme.com
(See page 51 for details to Order On-Line)

Disclaimer:

**Brand names and trademarks published herein are registered trademarks of their respective companies. Birk & Blyme is not an authorised dealer of these companies. All mentioned spare parts are alternative parts to those of the OEM. Birk & Blyme supply compatible high quality replacement parts. All indicated reference numbers are only used for identification purposes.*

MBO* Style Blades

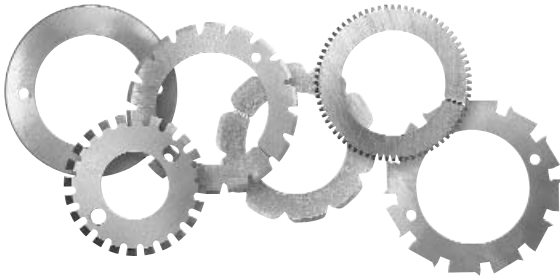

Perforators

OEM #	Inside dia	Outside dia	Number of Teeth	Cut	Tie
2.0.5591.030	35	53	15	7	3
2.0.5591.040	35	53	22	3	5
2.0.5591.050	35	52.5	42	2	2
2.0.5591.060	35	52.5	70	1.3	1.0
2.0.5591.070	35	53	12	11.2	2.5
50-210-040	40	61.5	8	21	3
50-210-050	40	61.5	12	13	3
50-210-060	40	61.5	18	8	3
50-210-070	40	61.5	28	2	4.9
50-210-210	40	61	28	5	1.8
50-210-230	40	60	80	1	1
50-210-240	40	60	48	2.5	1.5
50-210-410	40	61.5	12	10	6
50-210-420	40	61.5	18	5.8	5
50-210-450	40	61.5	10	16.8	2.5
50-210-630	40	61.5	6	29.5	2.5
50-210-720	40	60	36	2.7	2.5
50-210-950 (solid)	40	60	36	4	1.2
50-210-970	40	61.5	16	8.5	3.5
50-211-160	40	61	15	8.8	4
50-211-190	40	61.5	12	12.5	3.6
50-211-620	40	61.5	12	13.1	3
50-211-630	40	61.5	16	8.5	3.5
50-211-640	40	61.5	18	7.7	3
505591060	40	61.5	18	4	7

Burst Perforators

OEM #	Inside dia	Outside dia	Thick	Teeth	Cut	Tie
2.0.5591.100	35	54	0.9	9	10.7	7.8
60-210-270	30	63.0	0.8	12	10.5	6
60-210-280	40	62.0	1.2	12	8.2	8
60-210-340	40	64.0	1.5	12	10.8	6

Slitters

OEM #	Inside dia	Outside dia	Thick	Type
2.0.5591.010	35	53.5	0.8	Solid
50-210-030	40	61.5	0.5	Split
50-210-250S	40	61.5	3.0	Solid
50-210-260	40	61.5	0.5	Solid
50-210-480	40	64	0.5	Solid
50-210-760	40	61.5	0.8	Solid
50-211-380	40	65.0	1.0	Solid
U-12692/TW	40	65.0	0.8	Solid

Scorers (Creasers)

OEM #	Inside dia	Outside dia	Thick	Type
2.0.5591.020	35	51.5	0.8	Solid
2.0.5591.080	35	50.8	0.8	Solid
50-210-020	40	59.5	0.8	Split
50-210-220	40	60	0.8	Split
50-210-850	40	61	0.8	Solid
50-210-860 (solid)	40	61.5	1.5	Solid

Crimping Perfs

OEM #	Inside dia	Outside dia	Teeth
50-210-740-S	40	61	24
50-211-050-S	40	62.5	24

Crimping Perfs holds sheets together temporarily. Used for processing Zig Zag folded sheets on a gather stitcher and envelopes on a perfect binder.

*Brand names and trademarks published herein are registered trademarks of their respective companies.

Birk & Blyme is not an authorised dealer for Stahl and MBO products and do not offer genuine parts. Birk & Blyme supplies compatible high quality replacement parts

STAHL* Style Blades

Perforators (0.5 mm thick)

OEM #	Inside dia	Outside dia	Number of Teeth	Cut	Tie
217-636-02	26	37.5	60	1	1
200-750-02	30	48	10	12	3
200-750-01	30	48	15	7	4
200-759-03	30	48	18	6	3
205-990-10	30	48	24	5	2
200-758-01	30	46	30	3	2
200-758-02	30	48	30	3	2
200-758-03	30	46	40	2	2
205-985-03	30	44.6	60	2	1
205-985-04	30	45	60	1	1
200-758-05	30	45.5	60	2	1
200-758-06	30	48	60	2	1
200-759-06	30	48	72	1	1
200-756-07	40	61.5	6	29	3
200-756-08	40	61.5	8	21	3
200-756-13	40	61.5	10	17	2
200-749-01	40	62	12 std	13	3
205-978-01	40	62	12 rev	13	3
226-350-01	40	61.5	12	11	5
200-756-09	40	61.5	15	10	3
200-769-01	40	62	15	7	6
200-749-02	40	62	18 std	7	4
205-978-02	40	62	18 rev	8	3
226-350-02	40	62	18	6	5
210-621-01	40	61.5	28	3	3
200-756-01	40	61.5	30	4	2
200-756-12	40	60	36	3	2
200-749-03	40	62	40	2	3
200-756-05	40	61.5	48	2	2
200-754-06	40	59	60	2	1
200-754-01	40	59.5	80	1	1
200-754-02	40	59.7	80	1	1
200-754-04	40	60	80	2	1
200-754-03	40	59	80	1	1
200-754-07	40	61.5	90	1	1

Burst Perforators

OEM #	Inside dia	Outside dia	Thick	Teeth	Cut	Tie
213-037-01	30	50.5	0.9	10	10	11
213-038-01	30	50.5	1.2	10	10	11
213-027-01	40	64	0.9	12	12	12
213-028-01	40	64	1.2	12	12	12

Slitters

OEM Ref #	Inside dia	Outside dia	Thick	Type
200-747-11	26	39	0.5	Split
200-747-10	30	46	0.5	Split
200-747-01	30	48	0.5	Split
200-747-04	40	60	0.5	Split
200-747-03	40	61.5	0.5	Split
200-747-06	40	62.5	0.5	Split
200-747-05	40	63.5	0.5	Split
226-341-02	30	47.5	1.0	Solid
205-970-05	30	48	2.0	Solid
205-970-04	30	51	2.0	Solid
205-970-01	40	61	2.0	Solid
226-341-03	40	61.5	1.0	Solid
205-972-03	40	64	2.0	Solid
205-970-02	40	64	2.0	Solid
u-12692/TW	40	65	0.8	Solid

Scorers (Creasers)

OEM #	Inside dia	Outside dia	Thick	Type
200-742-11	26	37.5	0.8	Split
200-742-01	30	46.5	0.8	Split
200-742-02	30	46	0.8	Split
200-742-05	40	61	0.8	Split
200-742-06	40	60	0.8	Split
200-742-09	40	59.5	0.8	Split
200-742-12	40	59	0.8	Split

Blade ID is always 5mm larger than shaft size!

*Brand names and trademarks published herein are registered trademarks of their respective companies.

Birk & Blyme is not an authorised dealer for Stahl and MBO products and do not offer genuine parts. Birk & Blyme supplies compatible high quality replacement parts

Various Blades

Herzog & Heyman* Style

OEM #	Inside dia	Outside dia	Blade Type	Notes
510039	30	49	Perforator	6 teeth
510040	30	49	Perforator	10 teeth
510142	30	48	Perforator	14 teeth
510041	30	49	Perforator	16 teeth
510143	30	48	Perforator	16 teeth
510264	30	48.8	Perforator	25 teeth
510042	30	49	Perforator	28 teeth
510098	30	49	Perforator	30 teeth
510120	30	49	Perforator	34 teeth
510139	30	48	Perforator	40 teeth
510121	30	49	Perforator	48 teeth
510162	30	49.5	Perforator	48 teeth
510313	30	49.5	Perforator	50 teeth
510140	30	48	Perforator	50 teeth
510159	30	48	Perforator	50 teeth
510159/52	30	52	Perforator	50 teeth
510133	30	48	Perforator	60 teeth
510163	30	49.5	Perforator	60 teeth
510274	30	48	Perforator	70 teeth
510043	30	49	Perforator	80 teeth
510207	40	62	Perforator	15 teeth
510270	40	61.5	Perforator	30 teeth
510208	40	61.5	Perforator	36 teeth
510209	40	61.5	Perforator	60 teeth
510210	40	61.5	Perforator	72 teeth
510273	30	49	Slitter	1 mm solid
510204	40	62	Slitter	2 mm solid
510206	40	60	Scorer	0.5 mm
510202	40	58.1	Anvil ring	4 mm

Shoei* Style

Part #	Inside dia	Outside dia	Blade Type	Notes
Shoei-15	50	68	Perforator	15 teeth
Shoei-20	50	68	Perforator	20 teeth
Shoei-30	50	68	Perforator	30 teeth
Shoei-45	50	68	Perforator	45 teeth
Shoei-Bst8	50	70	Burst Perf	0.7 mm
Shoei-Bst16p	50	70	Burst Perf	1.2 mm
Shoei-Slit	50	68	Slitter	0.5 mm

Bowe* Style

Part #	Inside dia	Outside dia	Blade Type	Notes
31902	20	47	Slitter	Upper Blade
31903	20	47	Anvil	Lower Blade

Rollem* Style

OEM #	Inside dia	Outside dia	Blade Type	Notes
Rol # 2	35	63.5	Perf 66T	66 teeth
Rol # 3	35	63.5	Perf 66T	66 teeth
Rol # 4	35	63.5	Perf 66T	66 teeth
Rol # 8	35	63.5	Perf 50T	50 teeth
Rol # 9	35	63.5	Perf 28T	28 teeth
Rol # 13	35	63.5	Perf 92T	92 teeth
Rol-Slit	35	63.5	Slitter	45° bevel
Rol-Anvil	35	63.5	Square	



Perforating & Slitting Wheels

To suit **Hunkeler, Cameron, LISA, Dusenbury, Kidder, Autobond** etc. Common blade size as per table.

Part #	Dimensions (OD x ID x thickness)	Machine
W13	76.2 x 19 x 5.2 mm	Giebeler, Dusenbury
W14	76.2 x 19 x 6.3 mm	Cameron, Hunkeler
W15	76.2 x 22 x 6.2 mm	Cameron, Kidder
W34	76.2 x 24 x 5.0 mm	Hunkeler, LISA
50001	2.475" x 1.375" x .012"	Autobond
50182	2.5" x 1.375" x .0625"	Autobond

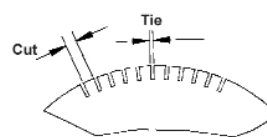

Cut and Ties

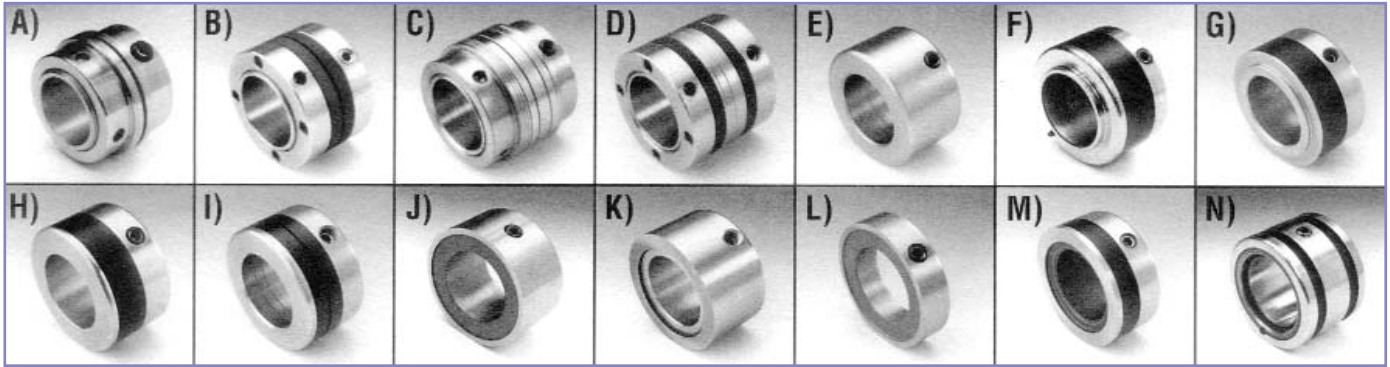

- We are able of supplying any configuration you desire from 1 tooth to 100 teeth per wheel.
- Ties from as small as .005" or as wide as 1.00"

*Brand names and trademarks published herein are registered trademarks of their respective companies. Birk & Blyme is not an authorised dealer for Herzog & Heymann, Shoei, Hunkeler, Bowe & Rollem products and do not offer genuine parts. Birk & Blyme supplies compatible high quality replacement parts



Item Description	Key	Mfg # For Shaft Size			
		Stahl* 25 mm	MBO* 30 mm	Stahl* 35 mm	MBO *35 mm
Blade Holder (standard)	A	203-559-BG-04	1.05539.010/020 35.5539.08	203-559-BG-01	01.5539.00/01
Edge Trim Blade Holder w/trim ring	B	203-559-BG-56		203-559-BG-47	
Centre Trim Blade Holder (old style)	C	203-559-BG-03	2.0.5539.020/030 1.0.5539.310/330	203-559-BG-02	1.0.5539.01/02
Centre Trim Blade Holder (new style)	D	203-559-BG-58		203-559-BG-49	
Transport Collar - Steel	E	203-558-BG-05	1.0.5339.310	203-558-BG-02	
Transport Collar -Rubber/Steel, w/ drive pin	F			202-845-BG-02	
Transport Collar -Rubber/Steel, Edge Trim	G	233-423-03-00		233-423-01-00	
Transport Collar -Rubber/Steel	H	203-558-BG-04		203-558-BG-01	50.220.010 01.5339.00
Transport Collar -Rubber/Steel, w/ groove	I	213-186-01-00		217-530-01-00	
Transport Collar/MBO* Uretane/Steel	**		35.5300.41		
Counter Knife (Anvil) - Steel	J	203-558-BG-06	2.0.5539.010	203-558-BG-03	50.210.010
Counter Knife (Anvil) -Steel w/ Bushing Burst perforating	K	203-558-BG-06SS		203-558-BG-03SS	
Counter Knife (Anvil) - Narrow 2 sided	L	25M-44M-14-DB		35M-58M-14-DB	
Counter Knife (Anvil) - Rubber/Steel	M	222-230-BG-03		222-230-BG-01	
Counter Knife (Anvil) - Tungsten Carbide	**			274-257-01-00	
Perforator Die Block	N			202-845-BG-04	
Transport Tyre	O	207-849-01	2.0.539-020		
Transport Hub with Tyre	P	207-832-01	2.0.539.010/020		

** Not shown

<h3>Transport Hub & Tyre</h3>  <p>P) O)</p> <p>See table above for Mfg #</p>	<h3>Grub Screws</h3> <p><i>Brass Tipped</i></p>  <p>Brass Tip</p> <table border="1"> <thead> <tr> <th>Ref #</th> <th>Size</th> <th>Fits</th> </tr> </thead> <tbody> <tr> <td>20091901 and 50.370.040</td> <td>8 x 8 mm</td> <td>Stahl, MBO</td> </tr> <tr> <td>23402601</td> <td>6 x 8 mm</td> <td>Stahl</td> </tr> <tr> <td>Herzgrub 6x6</td> <td>6 x 6 mm</td> <td>Herzog</td> </tr> </tbody> </table>	Ref #	Size	Fits	20091901 and 50.370.040	8 x 8 mm	Stahl, MBO	23402601	6 x 8 mm	Stahl	Herzgrub 6x6	6 x 6 mm	Herzog	<h3>T-Wrench</h3>  <p>4 mm T-Wrench - # BB1454</p>
Ref #	Size	Fits												
20091901 and 50.370.040	8 x 8 mm	Stahl, MBO												
23402601	6 x 8 mm	Stahl												
Herzgrub 6x6	6 x 6 mm	Herzog												

*Brand names and trademarks published herein are registered trademarks of their respective companies.

Birk & Blyme is not an authorised dealer for Stahl and MBO products and do not offer genuine parts. Birk & Blyme supplies compatible high quality replacement parts

Centre Trim Kits

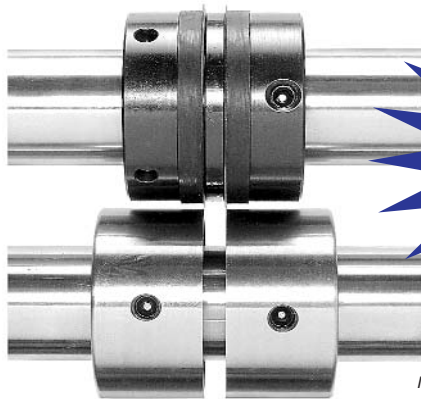

Includes Stripper not shown

Edge Trim Kits

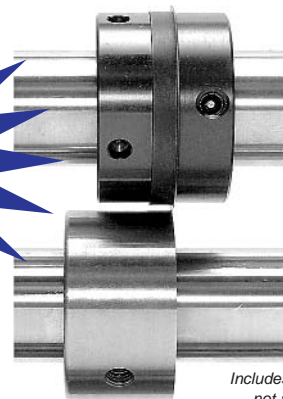

Standard

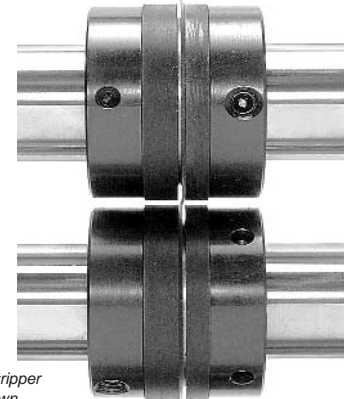

Includes Stripper not shown

Knife to Knife

Part #	Machine Model	Size
BB1006	Stahl/Stahl-O-Mat	1/8" (3 mm)
BB1005	Parallel	1/4" (6 mm)
BB1394	section only	3/8" (9 mm)
BB1395		1/2" (12 mm)
BB2464		1/8" (3 mm)
BB1976	Stahl T49, T50	1/4" (6 mm)
BB1977	T52 USA B-20	1/2" (12 mm)
BB1721	MBO T46, T49	1/8" (3 mm)
BB1722		1/4" (6 mm)
BB1723		3/8" (9 mm)
BB1724		1/2" (12 mm)
BB1725	MBO B23, 118	1/8" (3 mm)
BB1726	B-16/20, B-120	1/4" (6 mm)
BB1727	B-18, B-21	3/8" (9 mm)
BB1728		1/2" (12 mm)
BB1405	MBO B123	1/8" (3 mm)
BB1406	B26, B30	3/16" (5 mm)
BB1407		1/4" (6 mm)
BB1408		3/8" (9 mm)
BB1409		1/2" (12 mm)
BB1035	Stahl/Stahl-O-Mat	1/8" (3 mm)
BB1034	8 & 16 page sec.	1/4" (6 mm)
BB1398	TF56, 66, 78	3/8" (9 mm)
BB1399	TC56, 58, 66	1/2" (12 mm)
BB1978	MBO B26/32S	1/8" (3 mm)
BB1979	Perfection	1/4" (6 mm)
BB1980	Series	1/2" (12 mm)
BB1712	Stahl TD56, 6, 78	1/8" (3 mm)
BB1711		1/4" (6 mm)
BB1713		3/8" (9 mm)
BB1710		1/2" (12 mm)
BB2848	Stahl B-14/T36	1/8" (3 mm)
BB2849	Stahl B-14/T36	1/4" (6 mm)

STANDARD KNIFE TO KNIFE

Part #	Part #	Machine Model
BB1012	BB1013	Stahl-O-Mat T56 & T66 Par. only Stahl USA B-20
BB1041	BB1042	Stahl-O-Mat 8 & 16p sec, Stahl B23 TF56, 66, TC56, 58, 78
BB1718	BB1719	TD56, 66, 78
BB2846	BB2847	Stahl B-14
BB1026	BB1027	MBO T46, T49
BB1215	BB1720	B23-B16, B30, 35 mm
BB1391	BB1392	B123, B26, B30, 35 mm
BB1981	BB1982	MBO B26/32S Perf, Series, 35 mm

Knife to Knife Centre Trim Kits



Includes Stripper not shown

Part #	Machine Model	Size
BB1706	MBO B123	1/8"
BB1707	B26, B30	1/4"
BB1708		3/8"
BB1709		1/2"
BB1037	Stahl TF56, 66, 78	1/8"
BB1036	TC58, 56, 66	1/4"
BB1628	Stahl-O-Mat	3/8"
BB1629	8 & 16p sec.	1/2"
BB1702	Stahl TD56, 66, 78	1/8"
BB1703		1/4"
BB1704		3/8"
BB1705		1/2"
BB1983	MBO	1/8"
BB1984	B 26/32S	1/4"
BB1985	Perfection Series	1/2"

BURST PERFORATION KITS
Available on request!

*Brand names and trademarks published herein are registered trademarks of their respective companies.

Birk & Blyme is not an authorised dealer for Stahl and MBO products and do not offer genuine parts. Birk & Blyme supplies compatible high quality replacement parts



Centre Trim Spacers

25 mm shaft = 30 mm spacer
 30 mm shaft = 35 mm spacer
 35 mm shaft = 40 mm spacer

Part #	Machine Shaft Size	Knife Thickness	Trim width
BB2850	STAHL 20 mm	0.5	1/8" (3 mm)
BB2851		1.0	1/8" (3 mm)
BB2852		0.5	1/4" (6 mm)
BB2853		1.0	1/4" (6 mm)
BB1144	STAHL 25 mm	0.5	1/8" (3 mm)
BB1306		0.5	3/16" (5 mm)
BB1143		0.5	1/4" (6 mm)
BB1304		0.5	3/8" (9 mm)
BB1305		0.5	1/2" (12 mm)
BB1146	MBO 30 mm	0.5	1/8" (3 mm)
BB1307		0.5	3/16" (5 mm)
BB1145		0.5	1/4" (6 mm)
BB1309		0.5	3/8" (9 mm)
BB1308		0.5	1/2" (12 mm)
BB1656	MBO 35 mm	0.5	1/8" (3 mm)
BB1658		0.5	3/16" (5 mm)
BB1653		0.5	1/4" (6 mm)
BB1651		0.5	3/8" (9 mm)
BB1649		0.5	1/2" (12 mm)
BB1148	STAHL 35 mm	0.5	1/8" (3 mm)
BB1228		0.5	3/16" (5 mm)
BB1147		0.5	1/4" (6 mm)
BB1229		0.5	3/8" (9 mm)
BB1230		0.5	1/2" (12 mm)
BB1654	MBO 35 mm	1.0	3/16" (5 mm)
BB1655		1.0	1/4" (6 mm)
BB1660		1.0	3/8" (9 mm)
BB1650		1.0	1/2" (12 mm)
BB1462	STAHL 35 mm	1.0	3/16" (5 mm)
BB1463		1.0	1/4" (6 mm)
BB1464		1.0	3/8" (9 mm)
BB1465		1.0	1/2" (12 mm)
BB1656	MBO 35 mm	2.0	1/4" (6 mm)
BB1147		2.0	3/8" (9 mm)
BB1651		2.0	1/2" (12 mm)
BB1148	STAHL 35 mm	2.0	1/4" (6 mm)
BB1653		2.0	3/8" (9 mm)
BB1229		2.0	1/2" (12 mm)

All spacers thickness are compensated to allow for knife thickness.



Trim Rings

40mm trim ring goes on 35mm shaft, etc

Part #	Description (ID)
BB1413	26mm 1/4"
BB1001	30mm 1/4"
BB1002	30mm 1/4" with groove
BB1297	30mm 3/8"
BB1017	35mm 1/4"
BB1018	35mm 1/4" with groove
BB1298	35mm 3/8"
BB1030	40mm 1/4"
BB1031	40mm 1/4" with groove
BB1191	40mm 3/8"

Pull-Out Wheel Assembly



- Inexpensive replacement parts
- Fewer wearing parts
- Complete compatibility with original Stahl*

Part #	Machine Model
COMPLETE ASSEMBLIES	
BB1102	Fits Blue Line Stahl*-O-Mat, Flex-O-Mat & TC Series
BB1683	Fits Stahl* TD Series folders
BB1967	Fits MBO* B Series with extra pull out shaft
BB2620	Fits MBO* Perfection Series
BB2621	Fits Stahl* B-14 transfer table
REBUILD KITS (Spare Parts)	
BB1107	Upper & lower arm, spring to fit BB1102
BB1785	Upper & lower arm, spring to fit BB1683 & BB1967
BB2661	Replacement Tire for BB2621
BB2680	Replacement Tire for MBO* perfection
BB1108	Replacement Tire for BB1102, BB1683 & BB1967

Slitter Shaft Hanger

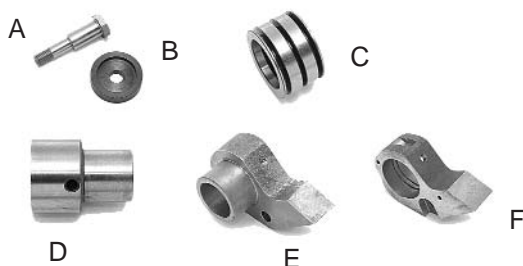

Part #	Key	OEM #	Description
BB2747	A	22939701	Hanger Pin for BB2729
BB2748	A	22935603	Hanger Pin for BB2746
BB2751	B	23173201	End Cap
BB2750	C	23179601	Compression Sleeve
BB2749	D	23173101	Bearing Bolt for Belt Shaft
BB2729	E	23191901	Hanger Slitter Shaft Removable Stahl TF/TC/TD
BB2746	F	23189303	Hanger Slitter Shaft Gear Side TF/TC/TD

*Brand names and trademarks published herein are registered trademarks of their respective companies.

Birk & Blyme is not an authorised dealer for Stahl and MBO products and do not offer genuine parts. Birk & Blyme supplies compatible high quality replacement parts

Stahl* Style Stripper Assemblies / Strippers



Centre Trim Stripper Assembly Stahl-O-Mat Parralel Sec only		Stripper only
BB1818	1/8"	BB1154
BB1819	1/4"	BB1150
BB1820	3/8"	BB1438
BB1821	1/2"	BB1410
Thumb Screw		BB1226
Clamp		BB1070
Spacer		BB1895



Centre Trim Stripper TF Series		Stripper only
BB1155	1/8"	BB1154
BB1151	1/4"	BB1150
BB1439	3/8"	BB1438
BB1417	1/2"	BB1410
Thumb Screw		BB1226
Clamp		BB1070



Perf Stripper 25 mm Shaft Stahl-O-Mat, Stahl B-20, TI Series		Stripper only
BB1175		BB1176
Thumb Screw		BB1225
Clamp		BB1103



Perf Stripper 35 mm Shaft		Stripper only
BB1177		BB1174
Thumb Screw		BB1225
Clamp		BB1070



Edge Trim Stripper Stahl-O-Mat, Stahl B-20, TF & TC Series		Stripper only
BB1167		BB1166
Thumb Screw		BB1225
Clamp		BB1130



Edge Trim Stripper Stahl TD Series		Stripper only
BB1619		BB1542
Thumb Screw		BB1225
Clamp		BB1196



Edge Trim Stripper Stahl T36/B14/TI36 Series		Stripper only
BB2232		BB1526
Thumb Screw		BB1218
Clamp		BB1069

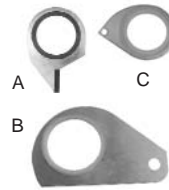

Burst Perf Strippers	Key
BB1444 (Ref # 224.739.BG01)	A (35 mm)
BB1444-1 (Ref # 224.707.BG01)	B (35 mm)
BB1444-2 (Ref # 224.767.BG01)	C (25 mm)



Knockout Perf Stripper Assy Stahl TF Series	Stripper only
BB2501	BB2798
Thumb Screw - Side	BB1226
Thumb Screw - Top	BB1218
Clamp	BB3093



Centre Trim Stripper Stahl TD Series		Stripper only
BB1620	1/8"	BB1536
BB1621	1/4"	BB1537
BB1622	3/8"	BB1438
BB1623	1/2"	BB1139
Thumb Screw		BB1226
Clamp		BB1070



Centre Trim Stripper Stahl B14/T36/TI36 Series		Stripper only
BB2866	1/8"	BB2729
BB2900	1/4"	BB2724
Thumb Screw		BB1223
Clamp		BB2320



Centre Trim Stripper USA B20 Series		Stripper only
BB2458	1/8"	BB2457
BB1989	1/4"	BB2724
Thumb Screw		BB1226
Clamp		BB1070



Centre Trim Deflector Stahl SOM,TF,TC Series		Stripper only
BB2502	1/8"	BB2499
BB2078	1/4"	BB2078
Thumb Screw		BB1225
Clamp		BB1070

*Brand names and trademarks published herein are registered trademarks of their respective companies.

Birk & Blyme is not an authorised dealer for Stahl and MBO products and do not offer genuine parts. Birk & Blyme supplies compatible high quality replacement parts

MBO* Style Stripper Assemblies / Strippers



Edge Trim Stripper Assy MBO T46/49	Stripper only
BB1418	BB1283
Thumb Screw	BB1218
Clamp	BB1203



Perforator Stripper Assy MBO T46/49	Stripper only
BB1419	BB1284
Thumb Screw	BB1218
Clamp	BB1203



Perforator Stripper Assy MBO B & Perfection Series	Stripper only
BB1275	BB1169
Thumb Screw	BB1218
Clamp	BB1203



Edge Trim Deflector Assy MBO T46/49	Deflector only
BB1420	BB1204
Mounting Screw	M6 x 20
Clamp	BB1073



Centre Trim Stripper Assy MBO B Series	Stripper only	
BB1188	1/8"	BB1172
BB1187	1/4"	BB1162
BB1586	3/8"	BB1585
Thumb Screw		BB1218
Clamp		BB1071



Edge Trim Deflector Assy B Series & Perfection Series	Stripper only
BB1168	BB1205
"L" Bracket	BB1244
Plastic Triangle	BB1206
Metal Triangle	BB1206
Thumb Screw	BB1203
Clamp	BB1218



Centre Trim Stripper Assy MBO B26/32S Perfection	Stripper only	
BB1986	1/8"	BB2224
BB1987	1/4"	BB2225
BB1988	3/8"	BB2226
Thumb Screw		BB2972
Clamp		BB2227



Edge Trim Deflector Assy MBO B26/32S Perfection	Stripper only
BB2230	BB2233
Locking Screw	BB2972
Clamp	BB2227



Centre Trim Deflector Assy MBO B Series	Deflector only
BB1161	BB1514
Extension Plate	BB1515
Thumb Screw	BB1218
Clamp	BB1513



Centre Trim Deflector Assy MBO Perfection Series	Stripper only
BB2231	BB2222
Thumb Screw	BB1218
Clamp	BB1513



Knockout Perf Stripper Assy MBO B18, B20, B118, B120, B23, B21	Stripper only
BB2616	BB2619
Thumb Screw	BB1221
Clamp	BB2617



Knockout Perf Stripper Assy MBO B123, B26, B30	Stripper only	
BB2615	0.63mm wide	BB2618
BB2682	1.0mm wide	BB2681
Thumb Screw		BB1221
Clamp		BB2617



Burst Perf Stripper	Stripper only
BB4055 (Ref # 4.0.5585.030)	

*Brand names and trademarks published herein are registered trademarks of their respective companies.

Birk & Blyme is not an authorised dealer for Stahl and MBO products and do not offer genuine parts. Birk & Blyme supplies compatible high quality replacement parts

Tri-Creaser *De-Lux*



The **END** of the Cracking Problem

The revolutionary TRI-CREASER totally eliminates fibre cracking and takes just minutes to set up - even by inexperienced operators.

The Tri-Creaser instantly transforms your existing folder into an intergrated folding and creasing machine with **PERFECT** results!

Tri-Creaser Main Benefits

- Specially developed for printers/print finishers who need to crease less than 150 gsm (very light stock) and more than 350 gsm (very heavy stock)
- Narrow creasing option perfect for 100 gsm stock (very light stock) and above
- Wide Creasing option for 350 gsm coated material and above (very heavy stock)
- Excellent on web/digital and perfect for pre-folded sections
- Unique 'rubber grippers' give extra support for sheet guidance
- Spare insert capacity built into side of device for easier and quicker set up
- Produces cylinder quality creasing on your existing folding machine
- Creases as fast as your folding machine can run

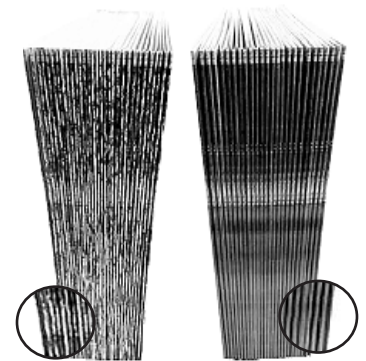
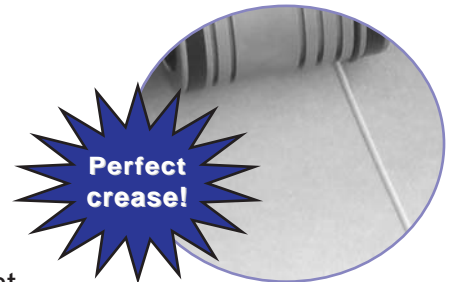

Without the Tri-Creaser **With the Tri-Creaser**

Part #	Device Description	Inserts** available	Machine type	Notes
TC-DEL-SM/35-FP	Tri-Creaser Delux to fit 35 mm shaft	orange, white	*Stahl, MBO	Each Tri-Creaser includes: Set of male and female collars 5 inserts for light/medium work 5 inserts for heavy work 1 Scriber tool. <i>(excl. Eurfold type)</i> **Each insert creases approx 1 million products before it needs replacing
TC-DEL-ST/25-FP	Tri-Creaser Delux to fit 25 mm shaft	red, pink	Stahl*, GUK	
TC-DEL-MF/30-FP	Tri-Creaser Delux to fit 30 mm shaft	red, pink	MBO*	
TC-STA-HH/30-FP	Tri-Creaser <i>Standard</i> to fit 30mm shaft	red, pink	Herzog & Heymann*	
TC-DIG-RO/20-FP	Rollem Tri-Creaser fits all types	orange, white	Rollem*	
TC-STA-HO/20-FP	Tri-Creaser <i>Standard</i>	red, pink	Horizon*	
TC-STA-SH/65-FP	Tri-Creaser <i>Standard</i> to fit 35ID- 65OD	orange, white	Shoei*	
TC-DEL-SH/55-FP	Tri-Creaser Delux to fit 35ID- 55OD	orange, white	Shoei*	
TC-DEL-HH/35-FP	Tri-Creaser Delux to fit 35 mm shaft	orange, white	Herzog & Heymann*	
DC-STA-MB/20-FP	Digi Creaser <i>Standard</i> to fit 5ID- 65OD	orange, white	MB- Cas 38/52 fold.	
TC-DEL-GU/35-FP	Tri-Creaser Delux to fit 35 mm shaft	orange, white	*GUK	
TC-STA-EU/10-FP	Tri-Creaser <i>Standard</i> to fit 15mm shaft	Black	Herzog & Heymann*	
TC-DEL-MG/15-FP	Tri-Creaser Delux to fit 15 mm shaft	orange, white	Morgana	

*Brand names and trademarks published herein are registered trademarks of their respective companies. Birk & Blyme is not an authorised dealer for Stahl, MBO, GUK, Herzog & Heyman, Shoei, Rollem and Horizon products and do not offer genuine parts. Birk & Blyme supplies compatible high quality replacement parts

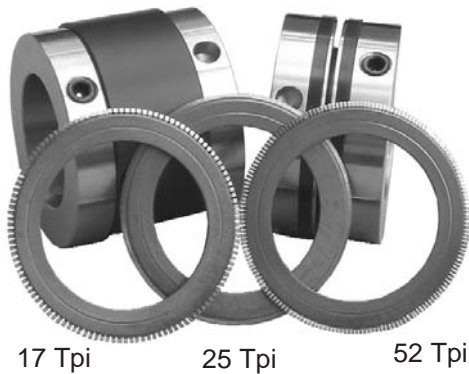

17 Tpi

25 Tpi

52 Tpi

Attaches to.....

Stahl* and MBO* folders

Micro Perf On Your Folder



Attach the Micro-Perf to your existing folding machine and within minutes you can get perfect perforating, even on light stock.

You can run the Micro-Perf alongside your existing Tri-Creaser's or any other manufacturer's equipment. That means you can crease and perforate in one easy pass **SAVING** huge amounts of time and money. No other simple and cost-effective system exists that enables you to transform your existing folding machine into a perfect perforating system.

- **Versatile:** 3 'Micro-Perf' attachments to suit light paper to heavy board (17, 25 and 52 Tpi -teeth per inch). Normal machine manufacturers ordinarily have just one perforating attachment at 12 Tpi.
- **Long Life Blades:** Each Micro-Perf is double bevelled which massively extends their longevity. Plus the Micro-Perf runs on to our unique nylon sleeve (not against metal) which means the Micro-Perf blade doesn't wear out.
- **Guaranteed Even Depth:** Quality of perforation is increased because the blades are mounted on our specially formulated rubber (Polyacetal) using our unique patented system. This ensures you get an even depth of perforation guaranteed every single time.
- **Quick Make-Ready Time:** Takes just a few minutes to set up and there's no need for training!

CP Appliator



The ultimate close proximity crease & perf applicator for most popular types of folding machines.

Now it is possible to produce two almost invisible micro-perforations as little as 5 mm apart. The impressive CP-Applicator includes creasing options that can easily be inserted into the middle of the two perforations to ensure quality fold position. This new system is perfect for companies looking for faster and more cost-effective ways of producing vouchers, tickets, coupons or rip-out order forms that need tear-off perms close to the fold.

The CP-Applicator is fully adjustable to allow quick change over of crease perf combination for any given format.

Attaches to..... **Stahl* and MBO* folders**

The Revolutionary CP - Applicator



- **Fully patented crease and micro-perforation technology**
- **Perf - Crease - perf (5mm - 45mm apart)**
- **Double perf (5mm - 50mm apart)**
- **Includes 17 Tpi (teeth per inch) 25 Tpi and 52 Tpi blades**
- **Includes 3 x crease styles (to suit 80 - 350 gsm)**
- **Almost invisible micro-perf result**
- **Operator friendly and easily adjustable**

*Brand names and trademarks published herein are registered trademarks of their respective companies.

Birk & Blyme is not an authorised dealer for Stahl and MBO products and do not offer genuine parts. Birk & Blyme supplies compatible high quality replacement parts

Multi-Tool



Produce multiple applications from one device
Slit • Trim • Kiss-Cut • Micro-Perforate • Edge-Trim

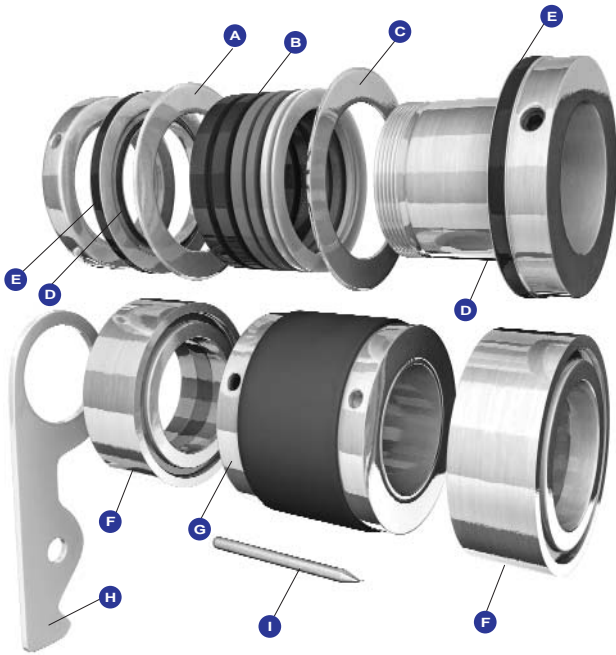

Multi-Tool Contents Diagram

Key	Description
A	Cutting blade (slitter). Standard and Kiss Cutting blade.
B	Spacer rings. The spacer rings are used to change the distance between blades when performing a double cut or perforation.
C	Micro-Perforation Blade. The Multi-Tool comes with 3 Micro-Perf blades; 17Tpi, 25Tpi and 52Tpi.
D	Blade fixing positions.
E	Gripper band. Substitute with the blue version for edge trimming using the Scriber toll (I).
F	Cutting bosses.
G	Nylon sleeve/holder keeps your blades in top condition.
H	Waste guide stops waste material from wrapping around your machine.
I	Scriber tool for changing rubber grippers.

The quality of cut and perforation is of a much higher standard than ever witnessed before on other rotary applications. The Multi-Tool can be purchased with **options 1-3** (Micro-Perf / Kiss-Cut), **options 4-6** (Cutting / Edge Trimming), or of course as the full package straight away (6 options)



1 Single Micro Perf

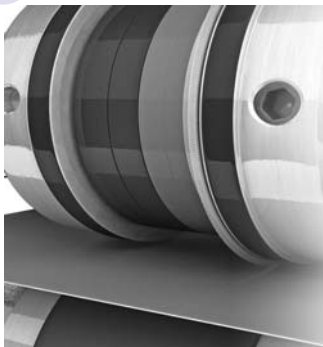

2 Double Micro Perf

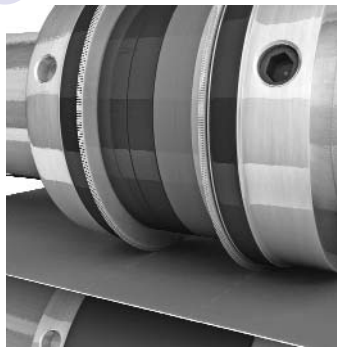

3 Kiss-Cut

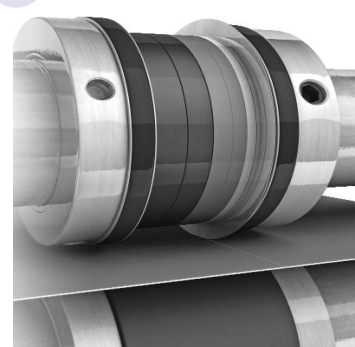

Options 1-3

4 Single Cut

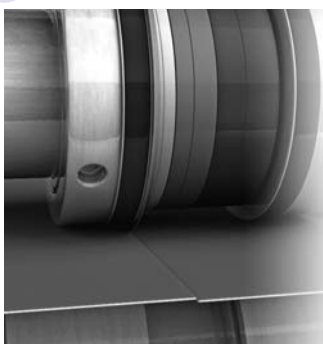

5 Double Cut

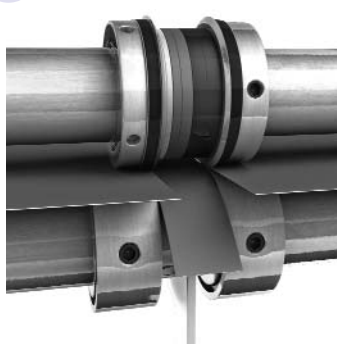

6 Edge Trimming

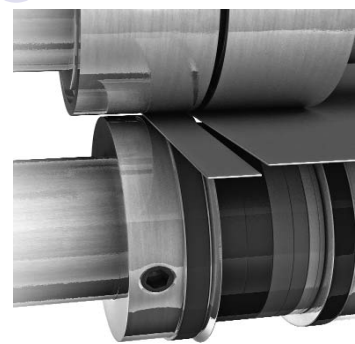

Options 4-6

The MULTI-TOOL is developed by **Tech-ni-Fold** to compliment their revolutionary Tri-Creaser

Roller Styles



Steel with Soft Polyurethane Rollers Stahl* Style



Spiral Rollers MBO* Style



Standard Steel/Urethane Rollers Stahl* Style

FOLD ROLLERS TIGER GRIP™

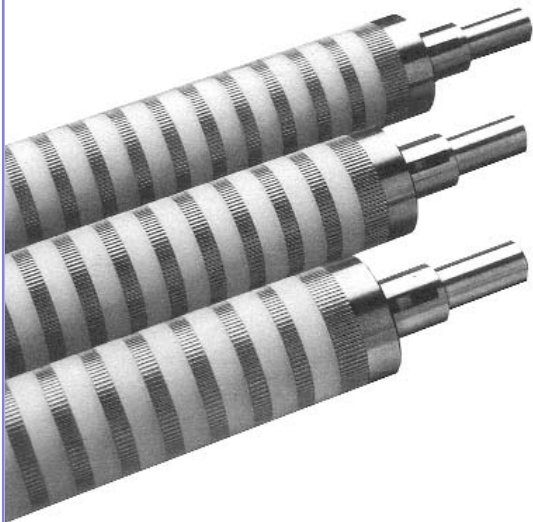

TIGER GRIP fold rollers are scientifically engineered with alternating sections of knurled steel and molded urethane.

TIGER GRIP fold rollers gives you the gripping power you want and the durability you need.

While we offer all roller styles: O.E.M. specified, rubber, steel or full faced, we strongly suggest that you give the **TIGER GRIP** a try.

When ordering or requesting a quote, please advise **Model, Station and Serial numbers** of your folding machine. This information is normally found on the model tags that are generally placed near the handwheel on the frame.

MBO* Style Serial plate (tag)

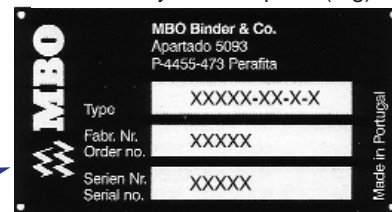

Stahl* Style Serial plate (tag)



*Brand names and trademarks published herein are registered trademarks of their respective companies.

Birk & Blyme is not an authorised dealer for Stahl and MBO products and do not offer genuine parts. Birk & Blyme supplies compatible high quality replacement parts



Glue Rollers



Is it a top quality combination fold roller or a segmented glue roller?

The Answer is **YES**.

Large 30mm diameter core is 50% more resistant to warping & bending

Knurled steel segments w/urethane for long life and quality folding whether you glue or normal folding. Simply separate the segments for relief when gluing, when not gluing slide segments back together to create a standard combination roller.

Stahl* Style

Part #	Machine Model
BB2079	TF56 before 5/89
BB2876	TF56 after 6/89
BB2316	T66 before 5/89
BB2062	TF66 after 6/89
BB2700	TF66 after 5/89
BB1939	TF78 after 6/89
BB2062	USA 26

MBO* Style

BB2270	B-123
BB1964	B-26
BB2452	B-30

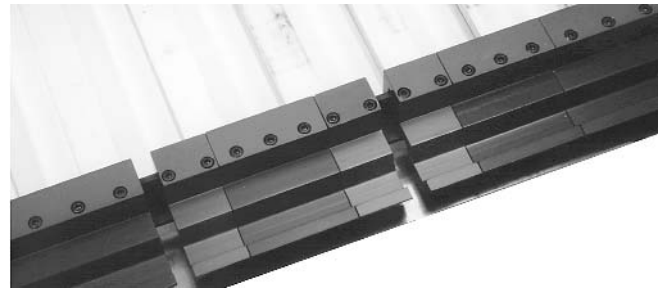

GLUE NOSES

Stahl* Style - with stationary deflector

Part #	Machine Model
BB2195	B-22/T56
BB1078	B-26/T66
BB2136	B-30/T78

Stahl* Style - with flip deflector

Part #	Machine Model
BB2196	B-22/T56
BB1077	B-26/T66
BB2135	B-30/T78

GLUE NOSES

MBO* Style

Part #	Machine Model
BB2197	B-123
BB2198	B-26
BB2026	B-30

MBO* Style

Part #	Machine Model
BB2107	B-20/B120
BB2563	B-118
BB2636	T-49

Replacement Segments Plate Nose & Roller

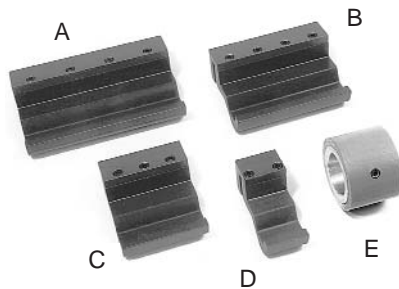
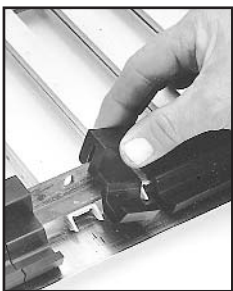

Part #	Key	Description
BB1754	A	Replacement Segment Stahl 4" long
BB1753	B	Replacement Segment Stahl 3" long
BB1752	C	Replacement Segment Stahl 2" long
BB1079	D	Replacement Segment Stahl 1" long
BB2199	A	Replacement Segment MBO B-26-30 4" long
BB2200	B	Replacement Segment MBO B-26-30 3" long
BB2201	C	Replacement Segment MBO B-26-30 2" long
BB2202	D	Replacement Segment MBO B-26-30 1" long
BB2105	B	Replacement Segment MBO B-120 3" long
BB2104	C	Replacement Segment MBO B-120 2" long
BB2103	D	Replacement Segment MBO B-120 1" long
BB1922	E	Replacement Roll Segment - before 1/1/02
BB2727	E	Replacement Roll Segment - after 1/1/02

*Brand names and trademarks published herein are registered trademarks of their respective companies.

Birk & Blyme is not an authorised dealer for Stahl and MBO products and do not offer genuine parts. Birk & Blyme supplies compatible high quality replacement parts

Poly V-Belts



Part #	Stahl* Ref #
BB1058	20043701
BB1059	20043702
BB1060	20146501
BB1061	20146601
BB1242	20146701
BB1383	21910101
BB1893	21206701
BB1384	21910104
BB1459	23164601
BB2163	31237
BB1534	20146301
BB1643	300J12
BB1644	300J8
BB2162	26131401

Part #	MBO* Ref #
BB2121	380J8
BB2124	340J6
BB2131	340J8
BB1534	400J8
BB2205	415J8 00107600
BB1060	430J8
BB2203	470J8 00107618
BB2204	480J8 00107681
BB2376	690J8 00107856
BB1789	360J8 00107557

Cogged Drive Belts



Part #	Stahl* Ref #
BB1381	20845001
BB1382	21355101
BB1443	20062001
BB1624	20062001
BB1674	20062002
BB2117	22X8X550

V-Belts



Part #	Stahl* Ref #
BB1062	20059408
BB1063	20059450
BB1064	20119201
BB1375	20059470
BB1376	20059221
BB1377	20119101
BB1380	20059449
BB1428	20059402
BB1607	20059401
BB1608	20059428
BB1648	20059479
BB1902	20059408
BB2466	20059441
BB2897	26765401
BB2898	20756
BB2899	26147301

Timing Belts

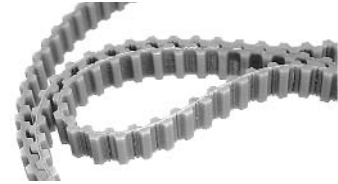

Part #	Stahl* Ref #
BB1378	20341602
BB1379	For fold plate (per foot)
BB1385	20347306
BB1386	20347311
BB1387	20347312
BB1388	20347313
BB1389	20347314
BB1390	22069101
BB2061	23743801
BB2164	110XL037
BB2377	23573701

Round Belts



Part #	Stahl* Ref #
BB2408	22106001
BB2409	22106002
BB2407	20189007
BB2411	20189012
BB1901	21277203
BB2407	20189017

- Sheets lay Flat
- Non stop feeding on copy machines - No jamming
- Per line is almost invisible
- Includes strippers (not pictured)

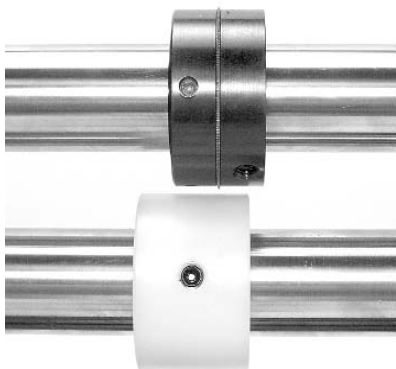

Plain paper



Standard perf

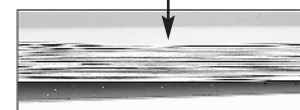

Micro paper

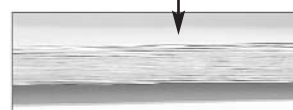

Micro Perf on your Folder

Part #	Description
BB2234	Complete Kit for 25mm shaft (*Stahl)
BB2235	Replacement Blade 25mm (*Stahl)
BB2236	Replacement Mandrel 25mm (*Stahl) B series
BB2237	Complete Kit for 30mm shaft (*MBO)
BB2238	Replacement Blade 30mm (*MBO)
BB2239	Replacement Mandrel 30mm (*MBO)
BB2032	Complete Kit for 35mm shaft (*Stahl)
BB2093	Complete Kit for 35mm shaft (*MBO)
BB2034	Replacement Mandrel 35mm
BB2033	Replacement Blade Standard
BB2116	Replacement Blade 50TPI 35 mm only

T-Wrench - 4 mm

Part # **BB1454**



*Brand names and trademarks published herein are registered trademarks of their respective companies.

Birk & Blyme is not an authorised dealer for Stahl and MBO products and do not offer genuine parts. Birk & Blyme supplies compatible high quality replacement parts

MBO* Style Cross Carrier Belts



Part #	OEM #	Description
BB2414	20x1x2750	T49
BB2415	20x1x2830	B115-B118, B120, B20
BB2416	20x1x3480	B23, 26, 30
BB2417	0106164	B26S/32S
BB2627	20x1x3080	B23, 26, 30, 16 page

Smoother Bar

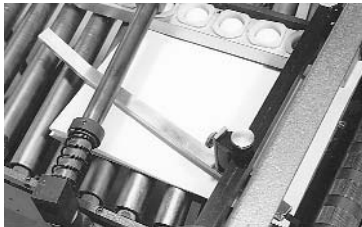

Part #	Description
BB1081	for Stahl SOM, TF, Stahl USA, B-26
BB2454	Stahl TD
BB2428	MBO 23, 123, 26, 30
BB2275	Replacement Spring Stahl
BB2360	Replacement Spring MBO

Split Guide Transfer Table Belts Stahl* & MBO Style



Part #	OEM #	Description
BB2633	22055401	Stahl Transfer Table B-14
BB2634	20062461	Stahl* ransfer Table TF56
BB2635	20062464	Stahl Transfer Table TF56
BB2628	870/830x20x1.8	MBO B-30
BB2629	765/730x20x1.8	MBO B-26
BB2630	680/645x20x1.8	MBO B-23
BB2631	925/880x20x1.2	MBO B-26S**

** MBO Perfection Series w/26" 8 page

Stahl* Style Cross Carrier Belts



Part #	OEM #	Notes
BB1368	20119005	<i>Original pink urethane covered by yellow cloth. Runs true.</i>
BB1368	21216401	
BB1369	20119001	
BB1369	20119011	

Stahl* Style Cross Carrier Sheet Guide

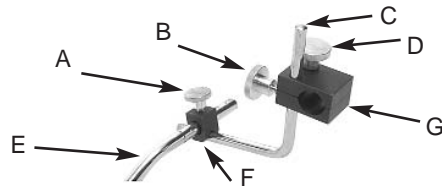

Part #	Key	OEM #	Description
BB1219	A	20061301	Thumb Screw
BB1218	B	20007003	Thumb Screw
BB2505	C	20587701	Hold down
BB1225	D	20007002	Thumb Screw
BB2508	E	215349BG03	Hold down Hollow
BB2507	F	21534501	Clamp
BB2506	G	20304301	2 pc Clamp

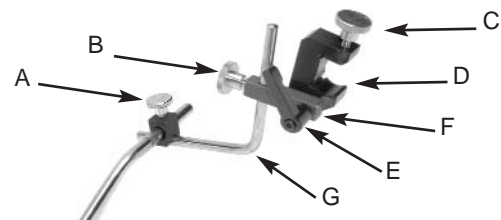

BB1219	A	20061301	Thumb Screw
BB1218	B	20007003	Thumb Screw
BB1225	C	20007002	Thumb Screw
BB1103	D	24702301	Clamp
BB1441	E	20021201	Clamp Lever
BB2854	F	209738BG07	Extension Block
BB2505	G	20587701	Hold down
BB2508	H	215349BG03	Hold down Hollow

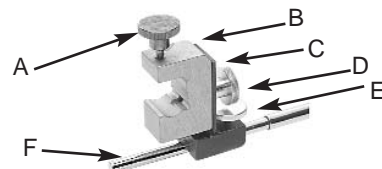

BB1225	A	20007002	Thumb Screw
BB2855	B	20417901	Clamp
BB2856	C	206093BG01	Clamp Sheet Guide
BB1218	D	20007003	Thumb Screw
BB2856	E	20007009	Thumb Screw
BB2511	F	21534605	Smoother Bar Solid

*Brand names and trademarks published herein are registered trademarks of their respective companies.

Birk & Blyme is not an authorised dealer for Stahl and MBO products and do not offer genuine parts. Birk & Blyme supplies compatible high quality replacement parts

MBO* style feeder parts

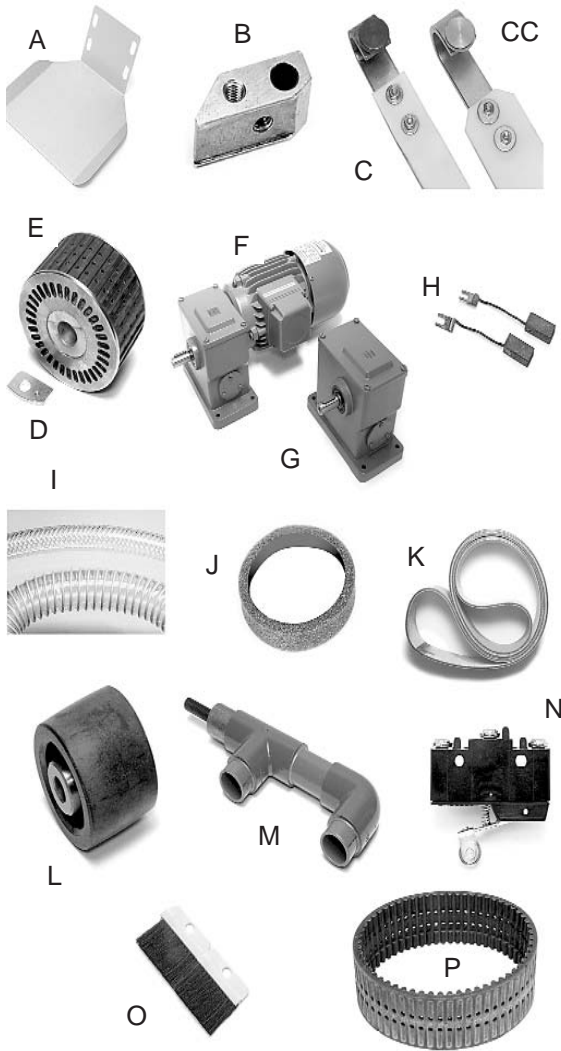

Part #	Key	OEM #	Description
BB2179	A	5.0.3661.020	Side Blower Part
BB2180	B	1.0.3544.010	Bearing Part
BB2089	C	0.1.3202.01	Teflon Strap 1"x13.750"
BB2090	C	0.1.3202.02	Teflon Strap 1"x30.750"
BB2167	C	0.8.3202.01	Teflon Strap 1"x11.500"
BB2168	C	0.8.3202.02	Teflon Strap 1"x35.500"
BB2386	C	n/a	Teflon Strap 1"x11.500"
BB2387	CC	2.0.3364.040B	Clamp for Teflon Strap, MBO B Series (20mm) Bar
BB2800	CC	2.0.3364.050	Clamp for Teflon Strap, MBO Perfection (25mm Bar)
BB2388	D	1.02244.020	Valve Bushing
BB2389	E	1.02200.351	Vacuum Wheel
BB2390	F	0104178	Motor Feeder Driver
BB2391	G	0104178GB	Gear Box only
BB2391	G	0104179	Gear Box only
BB2392	H	5.0.1171.680	Brushes for Motor
poa	I	n/a	Vacuum Tubing (on request)
BB2181	J	5.03239.010	Foam Ring
BB2393	K	20X1.3X2010	Feeder Drive Belt T-49
BB2393	K	00105791	Feeder Drive Belt B-115-118-120
BB2412	K	00105940	Feeder Drive Belt B-16-20
BB2394	K	20X2300	Feeder Drive Belt B-23-26-30
BB2395	K	00106055	Feeder Drive Belt B26S/B32S
BB2871	K	20X0.9X2280	Feeder Drive Belt B21
BB2349	L	00111781	Tape Roller
BB2396	M	5.0.3626-030/040	Side Blower Tube
BB2396	M	5.0.3600-270/040	Side Blower Tube
BB2692	N	BZ2RW82255-A2S	Pile Height Switch (MBO Pile Feed)
BB2692	N	00126565	Pile Height Switch (MBO Pile Feed)
BB2801	O	17.3244.02	Pile Back Stop Brush (Cont. Feed)
BB2801	O	3.06943010	Pile Back Stop Brush (Cont. Feed)
BB2875	P	17.2202.00	Vacuum Belt

Stahl* style feeder parts

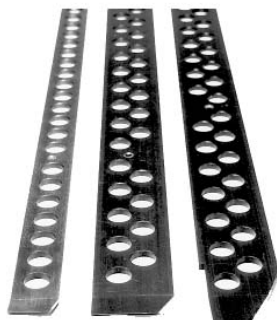

Part #	OEM #	Model	Size
BB1742	213-345-01	T56/66/SOM	Ball Carriers
BB1761	217-961-01	TF56/66/78 Cont.	Ball Carriers
BB1968	210-201-01	T49/50/TX52	Ball Carriers
BB2344	229-895-01	TC66	Ball Carriers
BB2344	229-896-01	TC66	Ball Carriers
BB2480	221-178-01	TF56/66/78 Pile Fd	Ball Carriers



Stahl & MBO* style Side Guides

Part #	OEM #	Model
BB1310	219-620-0110	B14/T36
BB2340	213-384-0300	T 50/52 TX52
BB1131	213-384-0200	T56/T66/T78 Stahl-O-Mat continuous or Pile Feed
BB1132	221-179-0100	TF56/TF66/TF78 Pile Feed
BB1133	217-962-0100 218-937-0100	TF56/TF66/TF78/94/112 continuous feed
BB1133	262-559-0100	Stahl* USA 24/26
BB1240	229-458-0100	TC58/TC66
BB1240	229-458-0200	TD56/TD66/TD78 (BB1240 will fit both models)
BB1698	260-201-0100	Stahl* USA/B20
BB1239	213-384-0100	T47/T49
BB1207	1.04263.330	MBO* B23/123/26/30
BB2873	35.4263.03	MBO B16,18,20/116/118/120

*Brand names and trademarks published herein are registered trademarks of their respective companies.

Birk & Blyme is not an authorised dealer for Stahl and MBO products and do not offer genuine parts. Birk & Blyme supplies compatible high quality replacement parts

Sheet Hold-down



- Superior sheet control for transfer to cross carrier
- Complete vertical & angle adjustment to maximise sheet control
- Shipped with different length springs to accommodate different size stocks
- Works great with panzer wheels for stacking small signatures and pieces

Part #	Description
BB2622	MBO Perfection Series
BB2623	MBO B Series
BB2624	Stahl and TF Series
BB2650	Replacement spring 8"
BB2651	Replacement spring 12"
BB2652	Replacement spring 18"

Marbles and Marble Cups

Marble Cups manufactured from high quality shatter resistant space age polymer.



Part #	Stahl* #	MBO* #	Description
BB1087	20063401	MBO20DIAP	20mm Plastic
BB1088	20013204	MBO20DIAS	20mm Steel
BB1089	20063402	N/A	24mm Plastic
BB1090	20013205	N/A	24mm Steel
BB1091	N/A	MBO25DIAP	25mm Plastic
BB1092	N/A	MBO25DIAS	25mm Steel
BB1093	20063403	N/A	35mm Plastic
BB1094	20013206	N/A	35mm Steel
BB1096	20677302	N/A	24mm Marble Cup
BB1098	20677402	N/A	35mm Marble Cup
BB2358	26102201	N/A	35mm Marble Cup

Idler Pulleys



Part #	Stahl* Reference #
BB1370	21209201
BB1371	21209301
BB1372	21209501
BB1373	21217301

Includes circlips & bearings

Crosscarrier Guide Spring



Part #	Stahl* Reference #
BB1639	227361BG09
BB1642	227361BG10

MBO* Style Marble Cup



** Not shown

Part #	Key	Description
BB2410	A	507200220 Marble Cup adjustable
BB2418	**	15720001 Marble non cup adjustable

Crosscarrier Guide Spring



Part #	Mfg #	Description
BB2328	21834601	U-joint
BB1342	21395301	Bearing - 4 required
BB2625	20397511	Spacer
BB2626	20397512	Spacer

*Brand names and trademarks published herein are registered trademarks of their respective companies.

Birk & Blyme is not an authorised dealer for Stahl and MBO products and do not offer genuine parts. Birk & Blyme supplies compatible high quality replacement parts

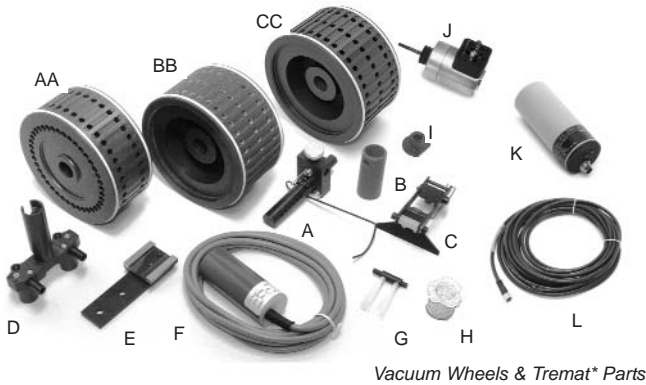

Vacuum Wheels

Part #	Key	OEM #	Description
BB1752	AA	200-960-BG01	Narrow Aluminium
BB1757	BB	228-146-0100	Wide Urethane Coated
BB2566	CC	233-002-0100	Wide Aluminium
BB1802	not shown	203-508-1200	O Ring B-14/Vacuum Wheel
BB1101	not shown	203-508-0600	O Ring/Vacuum Wheel

Tremat* Parts

Part #	Key	OEM #	Description
BB1126	A	221-874-BG02	Side Blower Assembly
BB1521	B	-	Bushing
BB1758	C	218-906-BG01	Choke Plate
BB1759	D	221-145-BG01	Suction Element
BB1760	E	212-350-BG01	Guide Bracket
BB1993	F	217-850-BG01	Reflex Head
BB2769	F	261-438-0100	Reflex Head
BB1794	G	212-334-BG01	Brush Only
BB1794	G	232-911-BG01	Brush Only
BB1949	H	212-349-0100	Sucker Carrier
BB2567	I	204-278-0100	Vacuum Bushing
BB2560	J	203-271-0100	Solenoid 24V DC
BB2575	J	230-511-0100	Solenoid 15V DC
BB2802	K	215-477-0200	Reflex Head
BB2803	L	-	Cable for Reflex Head
BB19-J	*	214-170-0100	Sucker Disc
BB1961	*	214-171-0100	Carrier Spring
BB1990	*	212-273-0100	Flat Spring
BB1991	*	203-508-0700	O-Ring
BB-1962	*	218-870-0100	Suction Element Spr.
BB-1992	*	214-197-BG01	Hose Complete
BB1963	*	210-989-0100	Micro Switch
BB2568	*	214-208-0100	Choke Plate Spring
BB2569	*	212-302-0100	Lifting Part Suction Ele
BB2570	*	216-296-0100	Spring Lifting Arm
BB2571	*	212-348-BG01	Angle Piece Complete
BB2572	*	216-317-0100	Brush Holder
BB2573	*	214-209-0100	Spring - Bush Adjusting

* Not shown

Continuous Feeder Transport Belts



Part #	OEM #
BB1862	213-447-0200
BB1863	213-447-0400
BB2358	213-447-0100
BB2359	213-447-0300

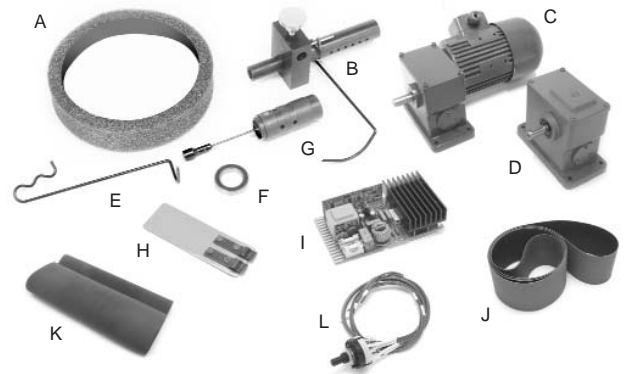

Continuous Feeder Parts

Part #	Key	OEM #	Description
BB2182	A	-	Foam Ring 100mm Wheel
BB2183	A	-	Foam Ring 135mm Wheel
BB1126	B	221-874-BG02	Side Blower Assembly
BB2398	C	203-464-0100	Feeder Drive Motor
BB2399	D	-	Gear Box Only
BB1129	E	221-876-0200	Replacement Spring for Blower RH
BB2364	E	221-876-0100	Replacement Spring for Blower LH
BB1127	F	221-875-0100	Replacement Bearing for Blower
BB1531	G	204-268-BG01	Plunger Valve
BB2802	H	213-325-0300	Sheet Guide
BB2738	I	227-794-0100	Feeder Motor Control Board
BB2770	J	263-629-0100	Cont. Fdr Table Extension Belt
BB2804	J	246-761-0100	Cont. Fdr Table Extension Belt
BB2805	J	218-938-0300	Cont. Fdr Belt TF56
BB2806	J	218-938-0100	Cont. Fdr Upper Belt TF66/78
BB2807	J	218-917-1200	Cont. Fdr Upper Belt Stahl 26
BB2808	J	218-917-0400	Cont. Fdr Drum Belt TF56/66/78-80mm
BB2809	J	218-917-0500	Cont. Fdr Drum Belt TF56/66/78-40mm
BB2810	J	218-917-1100	Cont. Fdr Drum Belt Stahl 26 - 40mm
BB2811	K	218-917-0700	Cont. Fdr Belt Lower Table TF56
BB2812	K	218-917-0600	Cont. Fdr Belt Lower Table TF66
BB2813	K	218-917-0300	Cont. Fdr Belt Lower Table TF78
BB2814	K	262-783-0100	Cont. Fdr Belt Lower Table Stahl USA
BB2815	L	220-946-0200	Vacuum Length Step Switch (suc length)
BB2816	*	220-945-0200	Sheet Spacing Potentioneter
BB1788	*	220-945-0100	Sheet Spacing Potentioneter (Double)
BB1163	*	n/a	Foam For Back Stop Wheels
BB2400	*	203-755-0400	Motor Brushes for BB2398

* Not shown

Trailing Bands



Part #	Description	Notes
BB2161	Clamp Only	
BB2318	Band Only	6" long, you cut to length
BB1224	Thumb Screw	
BB2319	Band Assembly	as shown

*Brand names and trademarks published herein are registered trademarks of their respective companies.

Birk & Blyme is not an authorised dealer for Stahl and MBO products and do not offer genuine parts. Birk & Blyme supplies compatible high quality replacement parts

Stahl* Style Infeed Belts

Belts produced by original manufacturer



Part #	OEM #	Model	Size
BB1367	221-056-01	T36/B14	1235 x 30 x 1.2
BB1699	200-626-13	T47/49	2260 x 50 x 1.2
BB1234	200-626-05	T56/66 SOM	2280 x 50 x 1.2
BB1587	200-626-02	TF56/66/78.a	2353 x 50 x 1.2
BB1365	200-626-20	TF56/66/78.b	2920 x 50 x 1.2
BB1237	200-626-22	TC58/66	2734 x 50 x 1.2
BB1237	232-798-03	TD56/66/78	2740 x 50 x 1.2
BB2101	262-723-01	B24/26	2873 x 50 x 1.2
BB2101	267-731-01	B24/26	2873 x 50 x 1.2
BB2576	200-626-20	TF56/66/78.b HD	2920 x 50 x 1.4
BB2577	267-731-01	B24/26 HD	2873 x 50 x 1.4

a. Pile Feed b. Continuous feed

MBO* Style Infeed Belts

Part #	OEM #	Model	Size
BB1233	n/a	B-123-26-30	50 x 1.2 x 2100
BB2031	n/a	T52	50 x 1.2 x 1790
BB1790	n/a	T47/T49 cont.	50 x 1.2 x 1804
BB2401	00106929	B26S/30S/32S Perfection	50 x 1.2 x 2425

Pre-wired Tremat* Micro Switch



- Includes new micro switches & wire
- Switches adjusted & ready to use
- Easy field replacement

Part # BB2397 (exchange)

Pre-wired Tremat* Micro Switch

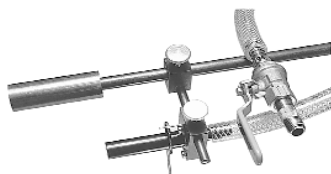

Kit Assembly
Part # BB1253

- Makes Stahl pile feeds operator friendly
- Greatly assists feeding on all stocks
- Complete kit for pile feed. Includes blower extension tube and on/off valve with instructions.

Register Board Pulleys, Idlers & Drive Belts



Part#	Key	OEM #	Description
BB1994	A	210-195-01	Front Idler Pulley-Stahl-O-Mat
BB1998	B	211-559-01	Jockey Wheel-Stahl SOM, TF Series
BB1997	C	216-931-01	Rear Idler Pulley - Stahl TF
BB1996	D	216-327-01	Front Idler Pulley - TF Series
BB1995	E	213-259-01	Rear Idler Pulley - Stahl-O-Mat
BB2000	F	213-370-01	Tape Roll
BB1625	G	213-460-01	Feeder Drive Belts - SOM
BB1599	G	213-460-05	Fdr. Drive belt-Stahl TF Cont.Feed
BB2002	G	213-460-02	Fdr. Drive Belt-Stahl TF Pile Feed
BB2536	G	262-930-01	Feeder Drive belt-Stahl USA 24/26
BB1999	H	213-533-01	Double Sheet Wedge
BB1171	I	211-004-02	Double Sheet Micro Switch
BB-2001	J	200-177-01	Jockey/Pulley/V-Idler Pulley
BB1476	K	200-584-10	Dbl. Sheet bearing-Stahl TF Series
BB1339	L	200-584-01	Dbl. Sheet Bearing - Stahl SOM
BB2402	M	213-404-01	Variable Speed Pulley
BB1824	N	201-354-01	Double Sheet Spring
BB2592	O	263-443-01	Splined Driv Pulley

Stahl* Style Side Blower Parts

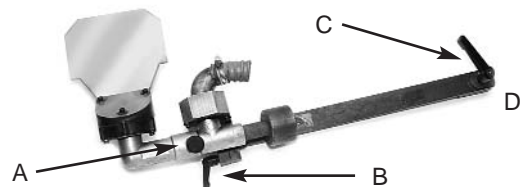

Part#	Key	OEM #	Description
BB1218	A	200-070-03	Thumb Screw
BB1441	B	212-200-01	Clamp Handle
BB2525	C	200-627-01	Clamp Handle (old style)
BB1801	C	200-627-02	Clamp Handle (new style)
BB2544	D	229-530-01	Clamp Lever Nut

*Brand names and trademarks published herein are registered trademarks of their respective companies.

Birk & Blyme is not an authorised dealer for Stahl and MBO products and do not offer genuine parts. Birk & Blyme supplies compatible high quality replacement parts

Stahl & MBO* Deflectors Quality Repair Parts



Part #	OEM#	Description
BB1665	217-570-01	T36/B14
BB1782	211-774-01	T47
BB1670	225-335-01	TX52
BB2321	211-774-02	T49
BB1360	200-362-11	T56 Stahl-O-Mat parallel section
BB1360	219-252-04	T56 Stahl-O-Mat parallel section
BB1076	219-252-01	T66 Stahl-O-Mat parallel section
BB1076	200-362-04	T66 Stahl-O-Mat parallel section
BB1361	200-362-03	*T56 Stahl-O-Mat 8,6,32 page sec.
BB1074	200-362-05	*T66 Blue Line, Stahl-O-Mat 8 page
BB1601	200-362-02	TF78 Fixed Deflector
BB1362	224-697-02	TF56, TD56
BB1075	224-697-01	TF66, TC66, TD66
BB1480	224-697-02	TF78, TD78

* Also fits early model TF series with fixed deflector

Part #	OEM #	Description
BB2819	12.5651.06	MBO B-123 Parallel & 8 Page
BB2820	01.5651.06	MBO B-26 Parallel & 8 Page
BB2821	01.5651.07	MBO B-30 Parallel & 8 Page
BB2822	01.5651.05	MBO B-123/26/30/16 page
BB2823	17.5651.12	MBO B-26S Parallel & 8 page
BB2824	17.5651.00	MBO B-30S Parallel & 8 page
BB2825	17.5651.24	MBO B-32S Parallel & 8 page
BB2823	17.5651.12	MBO B-30S&B323 W26" 8p
BB2826	10.5651.30	MBO B26-s/30S/32S/ 16 page

Also available, complete deflector frames to replace lost or damaged units

Stahl* Style Variable Speed Pulleys



Part #	OEM #	Description
BB1481	209-572-0100	Mechanical 24mm bore
BB1484	211-162-0100	Spring 1 side 19mm bore
BB1606	225-377-0100	Spring 2 sides 24mm bore
BB2688	225-377-0200	Spring 2 sides 24mm bore
BB2688	252-520-0100	Spring 2 sides 24mm bore
BB1673	207-841-0100	Spring 2 sides 19mm bore

Drive Shaft



Part #	Key	OEM#	Description
BB2007	A	214-914-BG08	Handwheel Shaft TF56 mfg. Before 1-85
BB2008	B	214-914-BG07	TF66 Mfg. Before 1-85
BB2009	C	219-221-BG04	TF56 Mfg. 1-85 thru 10-88
BB2010	D	219-221-BG03	TF66 1-85 thru 10-88
BB2011	E	228-519-04	TF56 11-88 to present
BB2012		228-519-03	TF66 11-88 to present
BB2013		218-581-01	Variable Speed Pulley Shaft TF56
BB2014		218-581-02	TF66

Jockey Wheels and Pulleys



* Not Shown

Part #	Key	OEM#	Description
BB1505	A	214-821-05	Pulley 10 Groove Poly-V
BB1780	B	200-738-01	Pulley 8 Groove Poly-V Drive
BB1781	C	200-739-01	Pulley 8 Groove Poly-V
BB2001	D	200-177-01	V-Belt Idler Pulley/Jockey Pulley
BB1082	E	200-799-01	Jockey Wheel Assembly
BB1082	E	200-799-02	Jockey Wheel Assembly
BB2578	F*	218-542-01	Pulley 8 Groove
BB2537	G*	215-908-01	Compression Bushing
BB2827	H*	203-425-BG24	Belt tens.Assy Stahl USA B-20
BB2828	H*	218-493-01	Belt Tensioner Pulley Only
BB1337	H*	200-584-07	Bearings for belt Tensioner

* Not shown

Fold Plate Stops



- Machine from steel for maximum strength
- Swivel stop is marked for plate/deflector position
- Includes all hardware

Part #	Reference #
BB1681	215-988-BG03
BB1681	215-988-BG04
BB1475	217-680-BG01

*Brand names and trademarks published herein are registered trademarks of their respective companies.

Birk & Blyme is not an authorised dealer for Stahl and MBO products and do not offer genuine parts. Birk & Blyme supplies compatible high quality replacement parts

Plate Clamp Levers

w/durable die cast zinc handles



Part #	OEM #	Description
BB1441	212-200-01	Clamping Lever Assy M6x25
BB1645	222-608-02	Clamping Lever Assy M8x25 Brass
BB1801	200-627-01	Clamping Lever Assy M8x25
BB1801	200-627-02	Clamping Lever Assy M8x25
BB1966	200-628-01	Clamping Lever Assy M10x50
BB2091	219-327-01	Clamp Lever M6x20
BB2100	227-981-BG01	Clamping Lever M8x65BT
BB2488	200-160-02	Clamp Lever

Plate Clamp Levers

w/durable die cast zinc handles



Part #	OEM #	Description
BB2125	204-306-BG08	B-14/T-36
BB1456	204-306-BG01	T-47, TF-56,66,78, TD-56,66,78 USA B24/26
BB2184	204-306-BG09	USA B20
BB2278	204-306-BG05	T-49
BB2279	204-306-BG07	T-50/T52

Plate Brackets



Part #	OEM #	Description
BB1829	212-964-01	Plt Bearing Bracket/Adj.Side w/o Micro Adj.
BB1829	215-228-01	Plt Bearing Bracket/Adj.Side w/o Micro Adj
BB1830	212-965-01	Plt Bearing Bracket/Non-Adj Side SOM 1&3
BB1831	212-965-01	Plt Bearing Bracket/Non-Adj.Side SOM 2&4
BB1832	230-307-01	Plt Bearing Bracket/Adj Side w/Micro Adj.
BB1832	232-454-BG01	Plate Bearing Bracket/Adj.Side w/Micro Adj. & Hand Numeric Indicator
BB1833	232-454-BG01	Plate Bearing Bracket/Non -Adj.Side TF, TC, TD, 1 & 3
BB1833	218-250-BG01	Plate Bearing Bracket/Non-Adj.Side TF, TC, TD 1 & 3
BB1834	232-454-BG02	Plate Bearing Bracket/Non-Adj.Side TF, TC, TD 2 & 4
BB1834	218-250-BG02	Plate Bearing Bracket/Non-Adj.Side TF, TC, TD 2 & 4
BB2841	215-128-01	Plt Bearing Bracket/Stahl USA 20 Adj side
BB2842	215-129-01	Plate Bearing Brac/Stahl USA 20 Non Adj.side 1&3
BB2843	215-129-01	Plate Bearing Brac/Stahl USA 20 Non-Adj.side 2&4



B-14/T36 Fibre Washers

Part #	OEM #	Description
BB1268	218-990-01	Fibre Washer
BB1269	218-990-02	Fibre Washer



Roller Lock Washers

Part #	OEM #	Description
BB1770	203-990-01	Lockwasher 15 mm ID
BB1503	216-049-01	Lockwasher 16 mm ID
BB1771	201-469-01	Lockwasher 20 mm ID

Stahl* Style TD USA Model Shims & Dust Seals

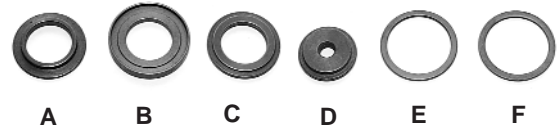

Part #	Key	OEM #	Description
BB2185	A	228-531-01	Gasket Ring
BB2186	B	228-532-01	Gasket Ring
BB2187	C	228-531-02	Gasket Ring
BB2188	D	228-534-02	Thrust Washer
BB2189	E	228-53-01	Spacer
BB2190	F	228-535-02	Dust Seals



Roll Hangers

Part #	OEM #	Description
BB2015	202-794-00	Stahl-O-Mat #1
BB1903	207-800-01	Stahl-O-Mat 2-5
BB2016	218-968-BG01	Stahl TF #1 Before 11/88
BB1904	219-214-BG02	Stahl TF 2-7 Before 11/88
BB2017	219-214-BG03	Stahl TF#1 Before 11/88 to present
BB1905	219-214-BG04	Stahl TF # 2-7 11/88 to present
BB2018	201-159-01	Graduated Ring
BB2019	201-482-01	Thrust Plate
BB2020	201-276-01	Spring
BB2021	200-132-03	Steel Ball

*Brand names and trademarks published herein are registered trademarks of their respective companies.

Birk & Blyme is not an authorised dealer for Stahl and MBO products and do not offer genuine parts. Birk & Blyme supplies compatible high quality replacement parts

Micro Adjust for fold stop

Converts early model Stahl* fold plates to today's ease of operation.

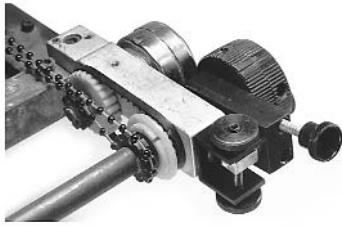

Part #	Description
BB1099	Stahl* SOM Early Model TF
BB2006	Stahl* USA B-20

Roll Gears



Part #	OEM #	Teeth	Description
BB1627	214-968-01	Gear 20T	Handwheel Shaft gear Par
BB2035	213-677-01	Gear 2T	Belt shaft Gear
BB2036	213-748-01	Gear 22T	Roll gear TF par
BB2037	214-969-01	Gear 19T	Idler gear
BB2038	214-967-01	Gear 29T	Stub Shaft TF Par
BB2039	208-712-02	Gear 15T	Idler gear TF SOM/8+16
BB2040	213-678-02	Gear 17T st	Belt shaft TF SOM/8
BB2041	208-715-01	Gear 16T st	Handwheel shaft/lower drive
BB2042	216-003-01	Gear 18T st	Roll gear TF 8+16 Page
BB2043	211-427-02	Gear 23T st	Stub shaft TF 8+16 Page
BB2106	201-939-02	Gear	T-49 roll gear

MBO* Style Clamp Levers

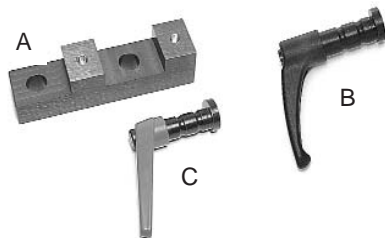

Part #	Key	OEM #	Description
BB2345	A	4.0.5115.020	Plate Clamp Bracket
BB2405	B	10.5125.02	Clamp Lev. Alum. Handle
BB2579	B	10.5125.02	Clamp Lev. Plastic Handle
BB2406	C	5.05125.010	Clamp Lever

Repair Parts for Stahl* Style gatefold plate

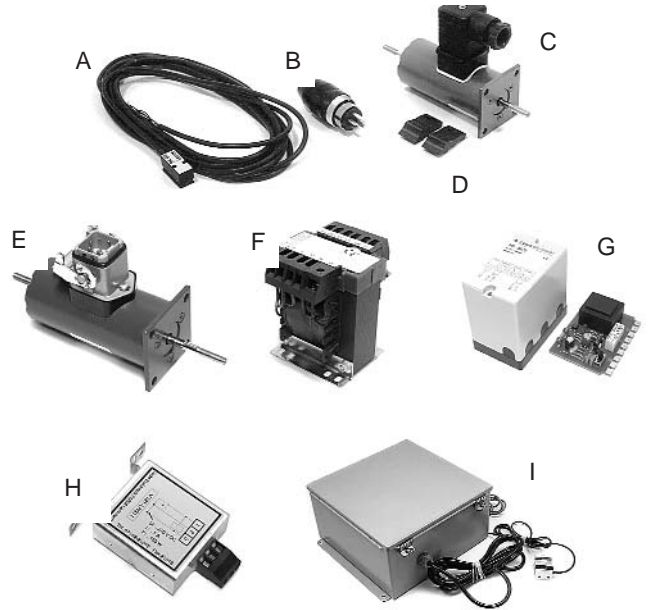

Part #	Key	OEM #	Description
BB1807	A	203-789-03	Photo Eye
BB2120	B	203-834-01	Photo Eye Plug
BB1613	C	203-765-01	Solenoid
BB1697	D	201-643-01	Control Fingers
BB2385	E	248-201-01	Solenoid
BB2384	F	203-843-01	Transformer
BB2374	G	210-672-01	Amplifier Board
BB2383	H	203-663-01	Spark Arrester
BB1696	I	n/a	Complete Electrical Control Box (will replace Stahl control box)



Roller Springs

Part #	OEM #	Description
BB1544	208-298-01	Compression Spring
BB1278	200-150-01	Compression Spring
BB1276	211-992-01	Extension Spring
BB2191	225-992-01	Extension Spring



MBO* Style Variable Speed Pulley

Part #	Key	OEM #	Description
BB2403	A	F100B	Variable Speed Pulley
BB2403	A	0104373	Variable Speed Pulley
BB2404	B	R100B	Variable Speed Pulley
BB2404	B	0104372	Variable Speed Pulley

*Brand names and trademarks published herein are registered trademarks of their respective companies.

Birk & Blyme is not an authorised dealer for Stahl and MBO products and do not offer genuine parts. Birk & Blyme supplies compatible high quality replacement parts

Plate Tensioner Assembly

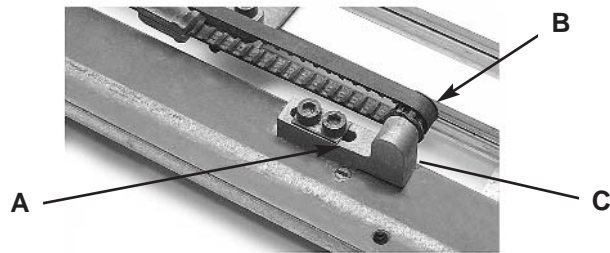

Part #	Key	OEM #	Description
BB2829	A	215-086-B601	Belt Tensioner Assy RH
BB2830	A	215-086-B602	Belt Tensioner Assy LH
BB2833	B	215-193-0100	Gear Pulley Only
BB2831	C	215-085-B601	Tensioner Fold Plate Blt Ass.RH
BB2832	C	215-085-B602	Tensioner Fold Plate Blt Ass.LH

Fold Plate Adjustment Mechanism

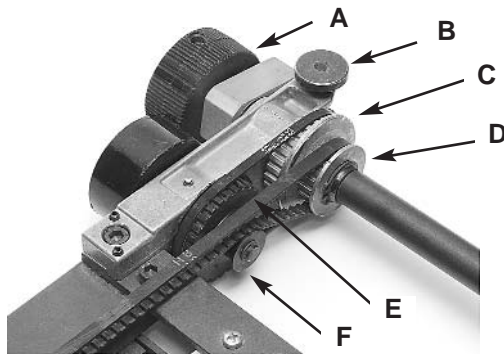

Part #	Key	OEM #	Description
BB2067	A	209-905-B601	Plate Adjustment Knob Assy.
BB1645	B	222-608-02	Clamp Lever
BB1509	B	200-073-01	Star Knob
BB2834	C	215-093-01	Aluminium Gear Pulley
BB2835	D	215-094-01	Aluminium Gear Pulley
BB2836	F	215-092-01	Plastic Gear Pulley
BB2837	F	215-087-01	Idler Pulley
BB1809	-	200-070-01	Thumb Screw

Fold Plate Adjustment Mechanism

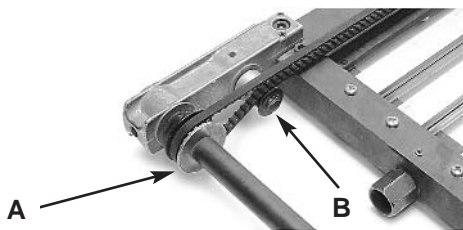

Part #	Key	OEM #	Description
BB2838	A	215-148-01	Aluminium Gear Pulley
BB2837	B	215-087-01	Idler Pulley

MBO* Style Fold Plate Parts

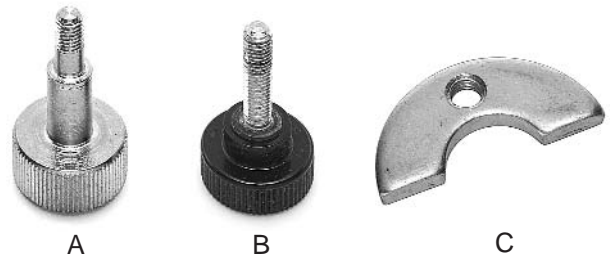

Part #	Key	OEM #	Description
BB2784	A	10.5629.01	Knurled Screw
BB2784	A	50-410-081	Knurled Screw
BB2839	B	M6x28GN421	Knurled Screw
BB2839	B	00095836	Knurled Screw
BB2840	C	3.05628.032	Locking Disc

Knife Folder Belts & Transport Belts

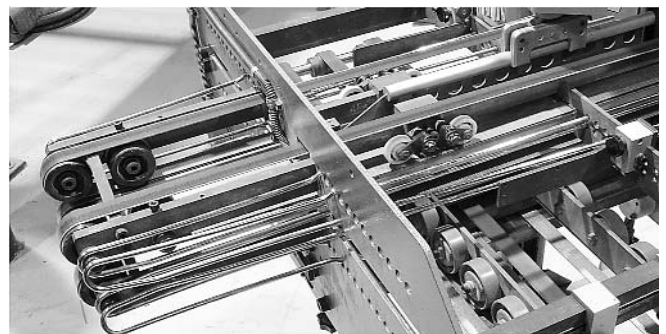

Part #	OEM #	Description
VFZ-52		
BB2638	220-037-3800	Transport Belt
BB2639	225-627-0200	Transport Belt
VFZ-43		
BB2640	220-037-3300	Transport Belt
BB2641	220-627-0100	Transport Belt
VFZ Drive Belts		
BB2642	225-631-0100	Drive Belt
BB2643	201-461-0200	Drive Belt
BB2644	225-632-0100	Timing Belt

MBO* Style Z-2 Knife

Part #	OEM #	Description
BB1329	20x1x520	Transport Band
BB2687	20x1x1555	Transport Band
BB1588	25x1x1750	Drive Belt

*Brand names and trademarks published herein are registered trademarks of their respective companies.

Birk & Blyme is not an authorised dealer for Stahl and MBO products and do not offer genuine parts. Birk & Blyme supplies compatible high quality replacement parts

Stahl* Style Bearings

All types of roller and needle bearings available. Please call for pricing



Teflon & Bronze Bushings

Part #	OEM #	Description
BB1455	200-671-01	Bz. Stacker Shaft
BB1488	204-812-04	Teflon Bushing
BB1322	213-861-04	Teflon Bushing
BB1321	213-601-01	Teflon Bushing

Needle Bearing & Grease Seals

Part #	OEM #	Description
BB1358	NK24/16	Needle bearing
BB1359	219-095-01	Needle bearing
BB2347	213-754-02	Needle bearing
BB2535	213-761-02	Needle bearing
BB1052	208-269-02	Needle bearing
BB1051	203-525-01	Needle bearing
BB1354	219-203-01	Needle bearing - TF 3PC
BB1355	219-215-01	Needle bearing
BB1800	228-500-01	Needle bearing - TC Style
BB1436	219-207-01	Flex 3 pce
BB1461	203-290-14	Blueline
BB1921	213-757-01	Rubber V ring
BB2185	228-531-01	Dust seal Stahl TD
BB2186	228-532-01	Dust seal Stahl TD
BB2187	228-531-02	Dust seal Stahl TD

Ball Bearing

Part #	OEM #	Description
BB1053	208-268-02	
BB1348	213-592-01	
BB1346	200-585-06	
BB1740	212-597-01	
BB1335	200-367-01	
BB1336	200-584-05	
BB1337	200-584-07	
BB1338	200-584-04	
BB1050	200-584-01	
BB1342	213-593-01	
BB1339	200-584-02	
BB1340	200-584-06	
BB1343	213-535-01	
BB1477	200-584-09	
BB1476	200-584-10	
BB1344	200-584-01	
BB1347	232-017-01	
BB1127	221-875-01	
BB1748	204-085-04	



MBO* Style Bearings

Part #	OEM #	Description
BB2349	F56202	Tape Roller
BB2349	00111781	Tape Roller
BB2348	80291	Bearing
BB2348	00111799	Bearing
BB1339	00109728	Bearing
BB1050	00109686	Bearing
BB1338	00109652	Bearing



MBO* Style Drive Belts

Part #	OEM #	Description
BB1588	25 x 1.3 x 1750	T47 / T49
BB1589	25 x 1.3 x 1540	B-123/26/30
BB2413	25 x 1.3 x 1290	B-123/26/30 2 plate
BB2004	25 x 1.3 x 2010	B-26S/30S/32S Perf Ser 4 plate
BB2005	25 x 1.3 x 2275	B-26S/30S/32S Perf Ser 6 plate
BB2119	25 x 1.3 x 1350	B- 16/B20
BB2896	25 x 1.3 x 1470	B-21
BB2529	25 x 1.3 x 2490	B-26S/30S/32S 4 plate w/pre slit
BB2530	25 x 1.3 x 2750	B-26S/30S/32S 6 plate w/pre slit
BB2845	25 x 1.5 x 2750	B-26S/30S/32S 6 plate w/pre slit*

*MBO Perfection Series *Heavy Duty 50% Stronger Break Strength



Handwheel Safety Clutch

Part #	Description
BB2192	Handwheel clutch - Stahl USA B-20
BB2174	Handwheel clutch - MBO
BB2193	Retaining nut only - Stahl
BB2194	Key - Stahl
BB2175	Retaining nut only - MBO
BB2176	Key - MBO
BB2580	Handwheel complete



MBO* Style Roller Adjustment Blocks

Part #	Key	Ref #	Description
BB2259	A	3.5.5326.020	Brass Adj. Piece
BB2258	B	1.0.5326.020	Brass Adj. Piece

*Brand names and trademarks published herein are registered trademarks of their respective companies.

Birk & Blyme is not an authorised dealer for Stahl and MBO products and do not offer genuine parts. Birk & Blyme supplies compatible high quality replacement parts

MBO* Style Slitter Shafts



- No Rusting
- No Marring
- Longer Wear

Part #	OEM #	Machine Model	Size
BB2206	1.5.5323.021	T-49	30mm
BB2207	35.5300.27	B-20	30mm
BB2281	35.5300.89	B-120	30mm
BB2208	1.23.5323.02	B-23	30mm
BB2282	12.5323.01	B-123	35mm
BB2209	01.5323.01	B-26*	35mm
BB2210	01.5323.02	B-30*	35mm
BB2283	17.5300.00	B-26S*	35mm
BB2284	17.5300.26	B-32*	35mm
BB2285	01.5323.00	B26/30 16p	35mm
BB2286	15.5300.10	B26S/B32S 16p	35mm

*Parallel: 8 page sections

Stahl* Style Slitter Shafts



Part #	OEM #	Machine Model	Size
BB1300	218426BG01	T-36/B-14	20mm
BB1300	218426BG02	T-36/B-14	20mm
BB1422	203444BG22	T-56 Stahl-O-Mat Par.	25mm
BB1134	203444BG19	T-66 Stahl-O-Mat Par.	25mm
BB1492	225545BG01	TX-52	25mm
BB1135	203444BG23	T-56 Stahl-O-Mat 8 & 16 p	35mm
BB1136	203444BG20	T-66 Stahl-O-Mat 8p	35mm
BB1135	203444BG23	TF-56/56.2 Flex-O-Mat	35mm
BB1136	203444BG20	TF-66/66.2	35mm
BB1535	203444BG25	TF-56.3/TC56/TD56	35mm
BB1506	234006BG01	TF-66.3/TC66/TD66	35mm
BB1522	234006BG03	TF-66.3/TC66/TD66	35mm
BB1777	231854BG04	TF-78.3/TC78.3/TD78	35mm

MBO* Style Slitter Shaft Support Pin



Part #	OEM #	Machine Model
BB2211	505325050 CPL	B26S/B32S Perfection
BB2212	105325380 CPL	B23 / B123 / B26 / B30
BB2213	105325082 CPL	T-47/49
BB2149	GN6336.1-40-M8-E	Knob Only



MBO* Style Slitter Bushing w/Pin

- Bushing manufactured to size with hole drilled
- Easy field replacement

Part #	Ref #	Description
BB1584	205326020	Brass Bushing

Stub Shaft Drive Coupling

Stahl* T & TF Series



Part #	OEM #	Description
BB2356	20010401	Circlip
BB1342	21359301	Ball Bearing
BB2609	20397508	Spacer
BB1348	21359201	Bearing
BB1181	21143201	Stub Shaft
BB1181	234128BG01	Stub Shaft
BB1181	225367BG01	Stub Shaft
BB1137	N/A	Drive Coupling

Stub Shaft, Bearings, Drive Couplings

Stahl* TF, TC, TD & USA Series



Part #	OEM #	Description
BB2610	20063702	Cup washer
BB2611	20010414	Circlip
BB1343	21353501	Bearing
BB1324	234007BG01	Stub Shaft
BB1442	N/A	Drive Coupling

Stub Shaft, Bearings, Drive Couplings

Stahl* B14 Series



Part #	OEM #	Description
BB1337	20058407	Bearing
BB1180	21841001	Stub Shaft
BB1700	N/A	Drive Coupling
BB2612	20010411	Circlip (not shown)
BB2613	20097219	Spacer (not shown)

Stub Shaft, Bearings, Drive Couplings



Part #	OEM #	Description
BB2614	21374101	End Cap
BB2537	21590801	Compression Sleeve
BB2612	20010411	Slitter Shaft ends - Removable Stahl TF56.3,66.3,TD & USA
BB1516	21605201	Slitter Shaft ends - Removable Stahl - TF
BB1776	20278701	Slitter Shaft ends - Removable Stahl-SOM

All slitter shaft removable ends are shipped complete w/bearings, circlip & spring washer.

*Brand names and trademarks published herein are registered trademarks of their respective companies.

Birk & Blyme is not an authorised dealer for Stahl and MBO products and do not offer genuine parts. Birk & Blyme supplies compatible high quality replacement parts

Delivery Wheel Assembly

Order extra wheel assemblies to handle those multiple up-jobs. Heavy duty design with bronze bushing.

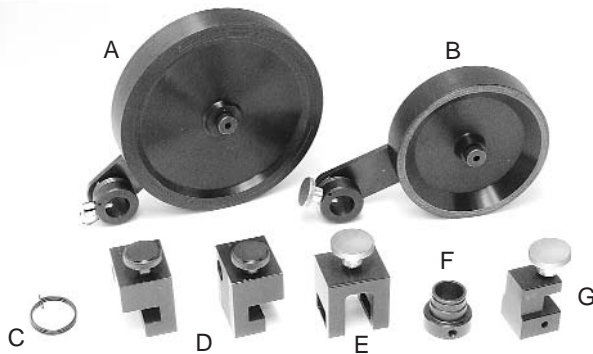

* Clamps made of durable aluminium

Complete wheel assembly

Part #	Key	OEM #	Description
BB1567	A	202278BG03	135mm wheel
BB1568	B	202278BG01	100mm wheel

Replacement Stacker Parts

BB1566	N/S	20228301	100mm wheel only
BB1565	N/S	20400901	135mm wheel only
BB1545	C	20228001	Spring
BB1826	D		Stacker wheel rod Clamp-MBO L&R
BB1497	E	20568401	Stacker guide holder
BB1570	F	20227901	Collar
BB2027	G	20228601	Stacker wheel rod Clamp -Stahl
BB145	**	20067101	Roll Bushing

Stacker Belts



Produced by original manufacturer

Part #	OEM #	Fits
BB1287	22533101	Stahl*
BB1311	22533102	Stahl*
BB1056	21258801	Stahl*
BB1057	22160501	Stahl*
BB2646	20062433	Stahl*
BB2489	21187402	Stahl*
BB2491	21187401	Stahl*
BB1231	40x1.3x1360	MBO*
BB2647	75x8.1x845	MBO*
BB2647	00106991	MBO*

Stahl* Style VSA Belts & Parts



Timing Belts

Part #	OEM #	Description
BB2061	23743801	Timing Belt
BB2377	23573701	Timing Belt

Round Belts

Part #	OEM #	Description
BB2407	20189017	Round Belt
BB2411	20189013	Round Belt

Flat Belts

Part #	OEM #	Description
BB2683	23744901	Flat Belt
BB2684	23745001	Flat Belt

Stacker Spring



Part #	OEM #	Description
BB2689		Complete Assembly
BB2152	21075701	Stripper spring only

Drive Motor

Part #	OEM #	Description
BB2543	21005401	Motor gear box assembly
BB2542	N/A	Gear box only
BB2645	N/A	Motor Brushes only

Crowned Stacker Pulleys

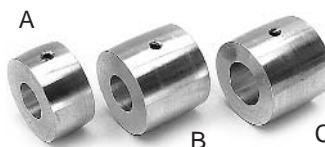

Machined from aluminium, not plastic. Set screw does not strip out.

Part #	Key	OEM #	Description
BB1267	A	20568501	25mm bore x 20mm wide tape
BB1265	B		25mm bore x 40mm wide tape. Used to convert early model stackers from 20mm wide to 40mm wide tapes.
BB1266	C	22154501	30mm bore x 40mm wide tapes

*Brand names and trademarks published herein are registered trademarks of their respective companies.

Birk & Blyme is not an authorised dealer for Stahl and MBO products and do not offer genuine parts. Birk & Blyme supplies compatible high quality replacement parts

Deluxe Stitcher Heads



18D



26/26D



G20



G8



G5

Head	Capacity	Crown Size	Wire Size(s)	Minimum Head Centres	Stitch Speed
18D Suits AM Graphics Bielomatik, Will, Harris, H'berg, McCain, Sheridan	Two sheets to 9/16" (14 mm)	3/8", 1/2", 5/8", 3/4" (10,13,16 & 20 mm)	20-28 Gauge Round 19x21-1/2, 20x25, 20x24 and 21x25Flat. Hybar I & II and .020x.10 Ribbon wire	3" (75 mm) at all material thickness	16,000 stitches per hour
26/26D Suits Bourg, Duplo, Harris, H'berg, Horizon, McCain, + Stahl	Two sheets to 1/4" (10 mm)	5/16", 3/8", 1/2", 5/8" (8,10,13 & 16 mm)	21-28 Gauge Round and 21x25 Flat	1-7/8" (48 mm) for all material thickness	16,000 stitches per hour max.
G20 Suits AM Graphics Bielomatik, Will, Harris, H'berg, McCain, Sheridan	Two sheets to 3/4" (20 mm)	1/2" and 5/8" (13 & 16 mm) + 13/64" (5 mm) Loop	20-28 Gauge Round 19x21-1/2, 20x25, 20x24 and 21x25Flat.	2-3/4" (70 mm) at two sheets to 3/16" (4 mm) material thickness	18,000 stitches per hour and 12,000 per hour for loop heads max.
G8 Suits AM Graphics Bielomatik, Will, Harris, H'berg, McCain, Sheridan	Two sheets to 5/16" (8 mm)	1/2" (13 mm) 13/64" (5mm) Loop	23-28 Gauge Round 20x24, 20x25 and 21x25Flat.	2-3/64" (52mm) at two sheets to 1/16" (1.5mm) material thickness.	20,000 stitches per hour and 12,000 per hour for loop heads max.
G5 Suits Bourg, Duplo, Harris, H'berg, Horizon, McCain, Macey + Stahl	Two sheets to 13/64" (5 mm)	1/2" (12 mm) 13/64" (5mm) Loop	25-28 Gauge Round	1-1/2" (39mm) up to 1/32" (1mm) material thickness.	10,000 stitches per hour max

* Capacity based on 75gram/m² / 20lb paper



Bostitch Parts

We have replacement parts for all your exiting Bostitch bindery equipment, including Bliss Stitchers, AW Machines and Number 7, 15, 14, 17, 2, 18 and 19 Heads.



*Brand names and trademarks published herein are registered trademarks of their respective companies. Birk & Blyme is not an authorised dealer for Heidelberg, Harris, Horizon, Duplo, Bourg, McCain and Stahl products and do not offer genuine parts. Birk & Blyme supplies compatible high quality replacement parts

Muller Martini* Style Heads by Deluxe



DB75

Part # DB881.8070

Capacity: up to 5mm
Crown Size: 13mm
75mm c/c stitch

Interchangeable with Muller Martini* HK75 heads



DB75V

Part # DB881.8071

Capacity: up to 6mm
Crown Size: 13mm
75mm c/c stitch

Interchangeable with Muller Martini* HK75V heads



Capacity: 3mm
5mm loop
75mm c/c stitch
wire size 24-25 or 25-26
speed 10,000
stitcher/hour
Part # DB75VHD251/2L



DB45

Part # DB45HD257/16

Capacity: up to 3mm
Crown Size: 10mm
45mm c/c stitch

Interchangeable with Muller Martini* HK45 heads

Deluxe Stitcher Machines



M7



M17

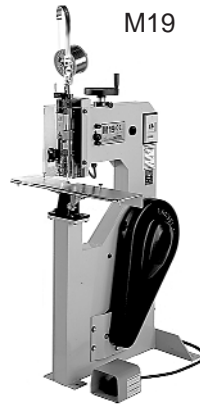

M19

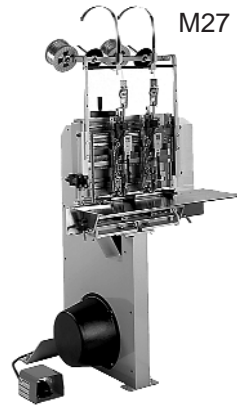

M27



M30

Model	Capacity	Replacement Head (s)	Wire Sizes
M7	7/8" (22 mm)	7000 HD, Crown width 9/16" (14.2 mm)	20x24, 20x25, 21x25 Flat, 24 through 28 Round. Can be equipped 19x21-1/2 parts for extended heady-duty work.
M17	1/4" (6.35 mm) with 26D 5/16" (6.35 mm) with G8	2 heads included: 2601MHD251/2. Crown width 1/2" (12.7 mm) or G8MHD241/2 (14mm). Uses up to 10 heads or 8 G8 Heads	23-28 Round Wire 21x25 Flat Wire
M19	9/16" (14.2mm) with 18D 3/4" (20mm) with G20	18001BHD20241/2	20x24, 20x25, 21x25 19x21.5" Flat and 20-25 Round wire.
M27	9/16" (14.2 mm)	2 heads included: 18001DHD. Crown width 1/2" (12.7mm). Uses up to 4 heads, 3" (47.6mm) centers. (can be fitted with either 18D or G20 Heads)	25-28 Round. Can be equipped with 21x25 Flat wire parts.
M30	Two sheets to 1-1/4" (32 mm). Up to 2" (50 mm) Stab Stitch.	One (side feed style)	20-25 Round wire and 20x24, 20x25, 21x25, 19x21-1/2" and 18x20 Flat wire.

* Some wire configurations require optional parts - Capacity based on 75gram/m² / 20lb paper

*Brand names and trademarks published herein are registered trademarks of their respective companies.

Birk & Blyme is not an authorised dealer for Muller Martini products and do not offer genuine parts. Birk & Blyme supplies compatible high quality replacement parts

18D Style

Sheridan
McCain
Harris
Bielomatic

26D Style

McCain
Heidelberg
Harris
Bourg
Duplo
Horizon

Muller Style

Muller
Osaka
Purlux

18D Style



26D Style



Muller* Style



Head	70/20 Stitcher Head	52/8 Stitcher Head	48/5s Stitcher Head	43/6 Stitcher Head	M50/8 Stitcher Head
Stitching Capacity	2 sheets to 3/4" (20mm)	2 sheets to 5/16" (8mm)	2 sheets to 1/4" (6.5mm)	2 sheets to 1/4" (6.5mm)	2 sheets to 5/16" (8mm)
Speed	1 to 18,000 cycles per hour	1 to 18,000 cycles per hour	1 to 12,000 cycles per hour	1 to 12,000 cycles per hour	1 to 18,000 cycles per hour
Crown Width	9/16" (14mm)	9/16" (14mm)	9/16" (14mm)	9/16" (14mm)	9/16" (14mm)
Wire Sizes	Round stitching wire: No. 23-28 (.025"-0.016") No. 20-23 (.035"-0.025") Flat wire 21x25, 20x24	Round stitching wire: No. 24-28 (.023"-0.015") No. 26-30 (.020"-0.014") Flat wire parts available	Round stitching wire: No.24-28 (.023"-0.015")	Round stitching wire: No.24-28 (.023"-0.015")	Round stitching wire: No.24-28 (.023"-0.015")
Net Weight	Net weight: 18 lbs.	Net weight: 9.9 lbs.	Net weight: 6 lbs.	Net weight: 4.2 lbs	Net weight: 7 lbs.
Centre to Centre The min. distance between staples depends on the stitching thickness.	Minimum distance between stitches: (70mm) 2-3/4"	Thickness 0 to 3/32" 1/8" 3/16" 1/4" 5/16" (max)	Distance Between 2 1/16" 2 3/32" 2 5/32" 2 3/16" 2 9/32"	Minimum distance between stitches: (48mm) 1 7/8" - 2 5/16"	Minimum distance between stitches: (45mm) 1 3/4" (50mm) 2"
Replaces	18D or G20 Heads	Most 26 style Stitching heads	Most 26 style stitching heads	Most 26 style stitching heads	Replaces HK55 and HK75 Muller Heads
Loop Head Kit	Loop Kit	Loop Head Loop Kit (6mm) Loop Kit (8mm)	Loop Head Loop Kit	Not available	Loop Head Loop Kit (6mm) Loop Kit (8mm)
Advantages	<ul style="list-style-type: none"> ■ Work on padline machines ■ Heavy Duty 	<ul style="list-style-type: none"> ■ Low maintenance ■ Heavy Duty 	<ul style="list-style-type: none"> ■ Narrow ■ Low maintenance ■ Reliable 	<ul style="list-style-type: none"> ■ Narrow ■ Low maintenance ■ Reliable 	<ul style="list-style-type: none"> ■ Narrower ■ Great capacity ■ Reliable

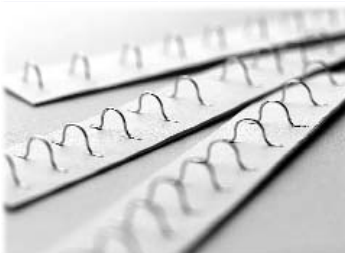

Loop Conversion kits available for Hohner Heads. Change from Standard Stitch to **Loop Stitch** in 15 minutes! Call for specifications and availability.

All HOHNER Spare Parts available. Please call for pricing. Fast turnaround.

Muller* Style



HSS-HK SYSTEM

New from Hohner. Designed to run on most Muller Martini* style machines, flying heads too!

The **HSS-HK** is specifically designed to retrofit Muller Martini, Osako and Purlux Saddlestitchers. With Hohner's new wire cutting technology, we can guarantee the reduction of wire gauge size by at least 1 gauge. The **HSS-HK** has also a reduced crown width of 12.7 mm down from 14 mm to add further savings in wire costs.

Available as a **2 or 4 Head System.**

- Minimum maintenance
- Highest quality
- Large savings on wire
- 40mm minimum centre to centre distance!
- New Cutting Technology

Call us for more information!

**See also Head Specifications as per table*

HSS HK Stitcher Head <i>(for HOHNER HSS-HK System)</i>	Exact Stitcher Machine	Orion IV Stitcher Machine
2 sheets to 5/16" (8mm)	2 sheets to 5/16" (1-4 52/8 heads)	2 sheets to 3/4" (1-4 70/20 heads)
1 to 18,000 cycles per hour	Max. 206 staples per minute, per head.	Max. 192 staples per minute, per head.
9/16" (14mm)		
Round stitching wire: No.24-28 (.023"-.015")	As per 52/8 Head Specifications	As per 70/20 Head Specifications
Net weight: 9.3 lbs.	146 Kg	605 Kg
Minimum distance between stitches: (40mm) 1.58"	As per 52/8 Head Specifications	As per 70/20 Head Specifications
Replaces HK55 and HK75 Muller Heads	n/a	n/a
Not available	Loop Head Loop Kit (6 + 8 mm)	Loop Kit
<ul style="list-style-type: none"> ■ Narrower (closest of any head!) ■ Low Maintenance ■ Huge Savings 	An option of one to four 52/8 stitching heads can be easily mounted for standard or loop stitching, or even mixed applications.	Solid construction, especially designed for producing thick pads with up to 4 heads simultaneously.



Order your Hohner Products and Spare Parts ONLINE @ www.order.birk-blyme.com

See page 51 for further details.

*Brand names and trademarks published herein are registered trademarks of their respective companies.

Birk & Blyme is not an authorised dealer for Muller Martini and Osako products and do not offer genuine parts. Birk & Blyme supplies compatible high quality replacement parts

DB75 Stitching Head

Similar to HK 75

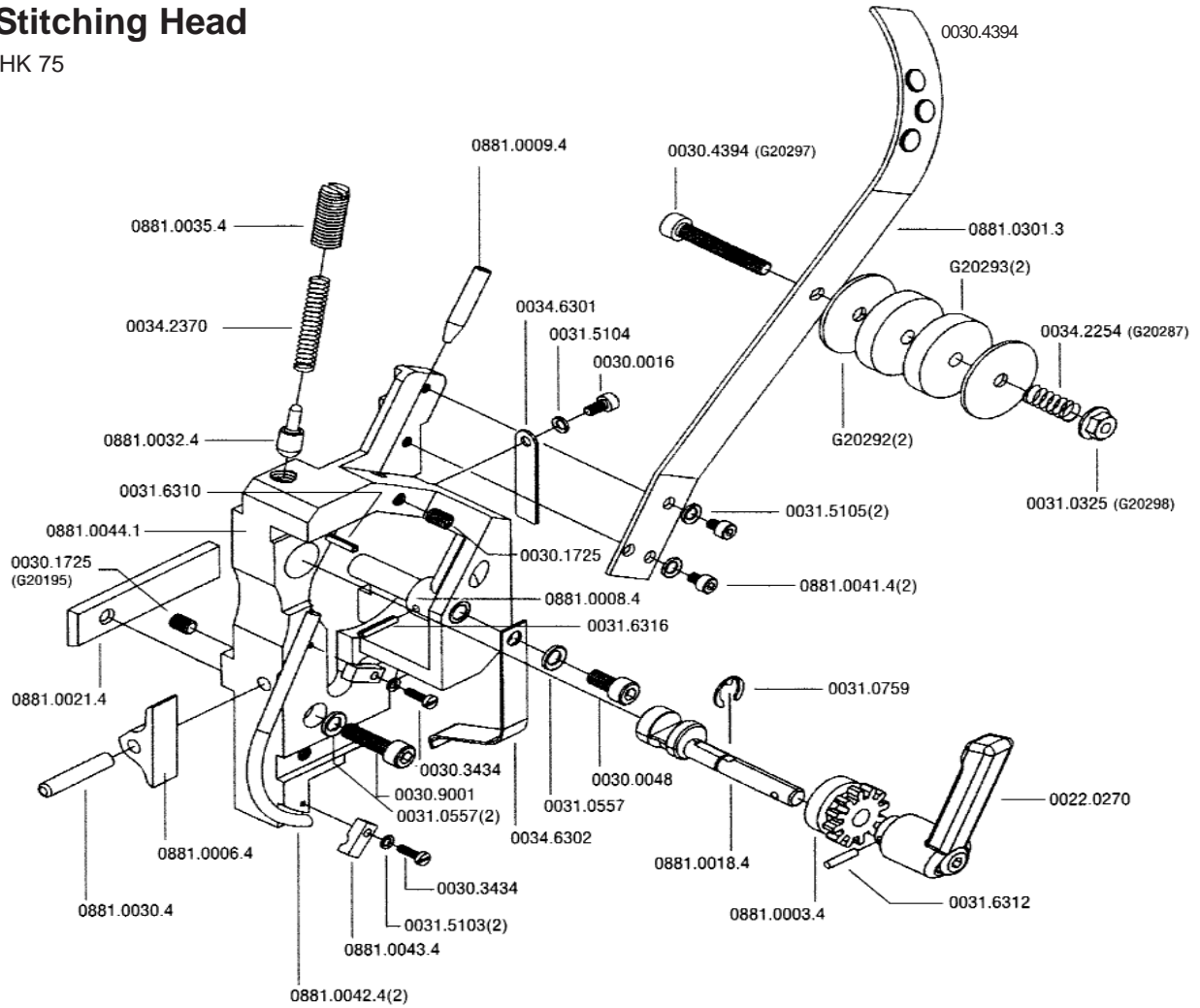

Bonnet & Wire Guide Sub-Assembly- DB75

Part #	OEM #	Description
G20287	0034.2254	Wire Oiler Felt Spring
G20292(2)	0881.0302.4	Wire Oiler Felt Washer
G20293	0881.0303.4(2)	Wire Oiler Felt
070119	0022.0270	Feed Release Handle
072001	0030.0016	Screw M4x0.7x8
072004	0030.0048	Screw M6x1x12
072009	0030.3434	Screw M3x0.5x10
(G20297)	0030.3494	Screw M6x1x40
072013	0030.9001	Screw M6x1x22
(G20298)	0031.0325	Hex Nut M6x1
071003	0031.0557	Lock Washer Ribbed
073002	0031.0759	E-Ring
071004(2)	0031.5103	Lock Washer Ribbed
071005	0031.5104	Lock Washer Ribbed
071006	0031.5105	Lock Washer Ribbed
073005	0031.6310	Spring Pin
073006	0031.6312	Spring Pin
073007	0031.6316	Spring Pin

Part#	OEM #	Description
074004	0034.2370	Compression Spring
070186	0034.6301	Friction Strip
070183	0034.6302	Wire Holder Retaining Spring
070112	0881.0003.4	Feed Gear, Small
070230	0881.0006.4	Cutter Operating Lever
070114	0881.0008.4	Feed Gear Shaft
070181	0881.0009.4	Upper Wire Tube
070118	0881.0018.4	Feed Release Cam Assembly
077006	0881.0021.4	Mounting Strap
073010	0881.0030.4	Dowel Pin M6x32
077009	0881.0032.4	Feed Cam Plunger
077010	0881.0035.4	Feed Cam Plunger Bushing
072017	0881.0041.4	Screw M5x0.8x5.5
070144	0881.0042.4	Wire Tube
070244	0881.0043.4	Wire Tube Clamp
070000	0881.0044.1	Bonnet DB75
070286	0881.0301.3	Wire Guide Spring

*Brand names and trademarks published herein are registered trademarks of their respective companies.

Birk & Blyme is not an authorised dealer for Muller Martini products and do not offer genuine parts. Birk & Blyme supplies compatible high quality replacement parts

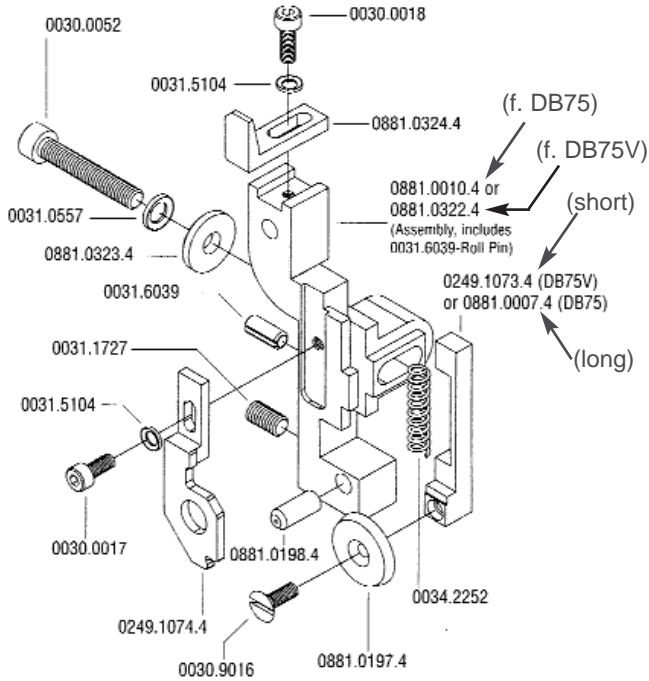

Cutter Box - DB75 - DB75V

Part #	OEM #	Description
072002	0030.0017	Screw M4x0.7x10
072003	0030.0018	Screw M4x0.7x12
072006	0030.0052	Screw M6x1.0x30
072014	0030.9016	Moving Cutter Screw
071003	0031.0557	Lock Washer Ribbed, (6mm)
071005	0031.5104	Lock Washer Ribbed, (4mm)
073004	0031.6039	Spring Pin
070210	0034.2252	Cutter Box Spring
070598	0249.1073.4	Cutter Operating Slide - DB75V
070206A	0249.1074.4	Wire Straightener Assembly
070198	0881.0007.4	Cutter Operating Slide - DB75
070197A	0881.0010.4	Cutter Box Assembly - DB75
070145C	0881.0197.4	Moving Cutter - Carbide
040145	0881.0025.4	Moving Cutter - Steel
070600C	0881.0198.4	Fixed Cutter - Carbide
070200	0881.0033.4	Fixed Cutter - Steel
070597A	0881.0322.4	Cutter Box Assembly - DB75V
071008	0881.0323.4	Washer
077026	0881.0324.4	Feed Gear Stop
G20229	0031.1727	Screw M6x1x12

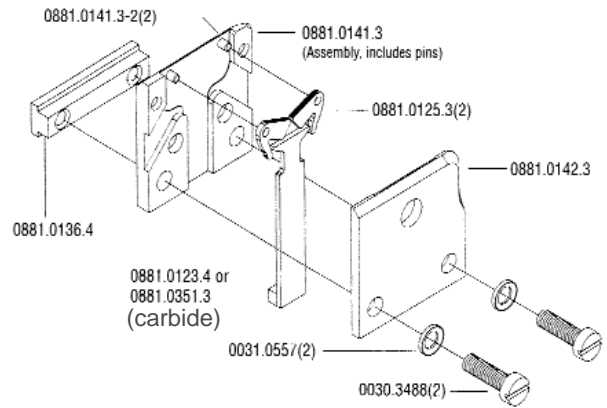

Clincher Plate Assembly - DB75 - DB75V

Part #	OEM #	Description
072012	0030.3488	Screw M6x1.0x20
071003	0031.0557	Lock Washer Ribbed, 6mm
077014	0881.0123.4	Clincher Slide Assembly - DB75
077029C	0881.0351.3	Clincher Slide (Carbide) - DB75V
077015	0881.0125.3	Clincher Point 1/2"
077017	0881.0140.3	Solid Clincher Plate Insert
077016	0881.0136.4	Clincher Mounting Bar
077018	0881.0141.3	Clincher Back Plate
07718-2	0881.0141.3-2	Clincher Point Pivot
077019	0881.0142.3	Clincher Front Plate
077030	0881.9050	Comp. Clincher Plate Assy- DB75

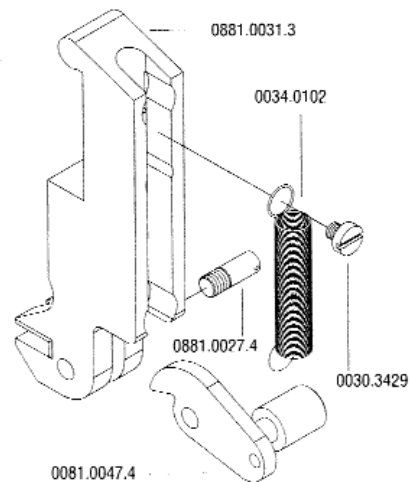

Wire Holder Assembly - DB75 - DB75V

Part #	OEM #	Description
072008	0030.3429	Screw, Cheese Head
074001	0034.0102	Extension Spring
073009	0881.0027.4	Hook Pivot Pin
070135	0881.0031.3	Wire Holder
077013	0081.0047.4	Wire Holder Hook Assembly
070135A	0881.0058.3	Complete Wire Holder Assembly

*Brand names and trademarks published herein are registered trademarks of their respective companies.

Birk & Blyme is not an authorised dealer for Muller Martini products and do not offer genuine parts. Birk & Blyme supplies compatible high quality replacement parts

DB75

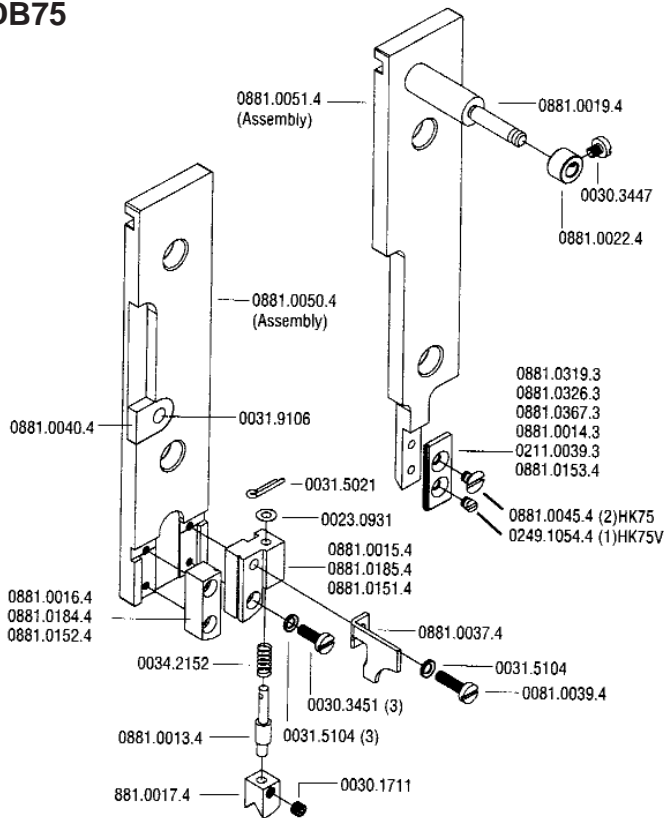

#25-28 Wire, use 0.6 mm Formers and Drivers
#22-24 Wire, use 0.8 mm Formers and Drivers
#20-24 Wire, use 1.0 mm Formers and Drivers

Online ordering!
www.order.birk-blyme.com

Please contact us for more information.

Drivers and Benders Inserts- DB75

Part #	OEM #	Description
071002	0023.0931	Shim Ring
072007	0030.1711	Screw M5 x 0.8 x 4
072010	0030.3447	Screw M4 x 0.7 x 5
072011	0030.3451	Screw M4 x 0.7 x 12
072015	0249.1054.4	Driver Retaining Screw
073003	0031.5021	Cotter Pin
071005	0031.5104	Lock Washer Ribbed M4
073008	0031.9106	Rivet
074003	0034.2152	Centre Guide Spring
070152-23	0211.0039.3	Driver 22-24 Wire (0.8) slot 1 side
077002	0881.0013.4	Centering Guide Post
070152-25	0881.0014.3	Driver 25-28 Wire (0.6) slot 1 side
070550R-25	0881.0015.4	Former RH 25-28 Wire (0.6)
070548L-25	0881.0016.4	Former LH 25-28 Wire (0.6)
077003	0881.0017.4	Centering Guide
077004	0881.0019.4	Driver Slide Shaft
077007	0881.0022.4	Set Collar
077011	0881.0037.4	Hook Guide, HK75
072016	0881.0039.4	Screw M4 x 0.7x 18.0
077012	0881.0040.4	Bender Slide Insert
072018	0881.0045.4	Screw M4 x 0.7 x 6
070162A	0881.0050.4	Bender Slide Assembly
070151A	0881.0051.4	Driver Slide Assembly
070550R-20	0881.0151.4	Former RH 20-24 Wire (1.0)
070548L-20	0881.0152.4	Former LH 20-24 Wire (1.0)
070152-20	0881.0153.4	Driver 20-24 Wire (1.0) slot 1 side
070548L-23	0881.0184.4	Former LH 22-24 Wire (0.8)
070550R-23	0881.0185.4	Former RH 22-24 Wire (0.8)
070552-20	0881.0319.3	Driver (1.0) slotted both sides
070552-25	0881.0326.3	Driver (0.6) slotted both sides
070552-23	0881.0367.3	Driver (0.8) slotted both sides

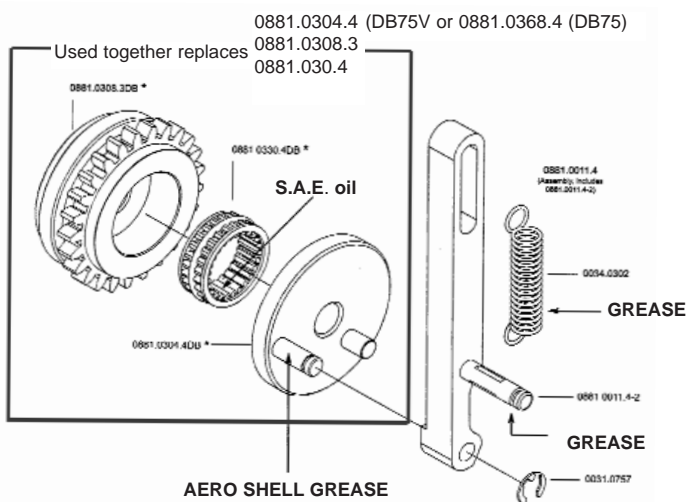

** Not interchangeable with Muller Martini (HK75, HK75V)

Feed Gear Assembly - DB75 - DB75V

Part #	OEM #	Description
073001	0031.0757	E-Ring
074002	0034.0302	Extension Spring
077001	0881.0011.4	Feed Gear Op. Lever assy.
077001B	0881.00114 Brass	Feed Gear Op. Lever assy.
070510A	0881.0308.3DB	Feed Gear Large DB75
088-150	0881.0308.3	Feed Gear Large HK75
070537	0881.0330.4DB	Feed Gear Clutch DB75
BB-0676	0881.0330.4	Feed Gear Clutch HK75
070511A	0881.0304.4DB	Feed Gear Pinion Ass. DB75V
088-149	0881.0304.4	Feed Gear Pinion Ass. HK75V
070111A	0881.0368.4DB	Feed Gear Pinion Ass. DB75
088-066	0881.0368.4	Feed Gear Pinion Ass. HK75

*Brand names and trademarks published herein are registered trademarks of their respective companies.

Birk & Blyme is not an authorised dealer for Muller Martini products and do not offer genuine parts. Birk & Blyme supplies compatible high quality replacement parts

Tech ni Fold

Spine-Creaser

A new development for cover feeders

Transform your cover feeder into a miniature Heidelberg* Cylinder with intergrated folding.



Attaches to... Muller Martini*, Heidelberg ST-100, ST-300*, Sheridan*, Osako*, Procetter*, Harris-Macey* etc.

- At least four times faster than the flatbed Cylinder
- Eliminates “fibre-cracking” even on coated cross grain stocks with heavy ink coverage
- No splitting. No ripping.
- Reverse crease method leads to superior quality every time.
- Easy fit, you can do it yourself in less than 10 minutes.
- Three crease width options (130-400gsm) including coated and cross grain materials with heavy ink coverage
- Perfect on laminated material and digital stock



Gathering Chain Carriers

Part #	OEM #	Description
BB01302	235.1302	Red Carrier (LHS) <u>without</u> bearing
BB01340	235.1340	Red Carrier (RHS) <u>without</u> bearing
BB03225	235.3225	Red Carrier (RHS) with bearing
BB03224	235.3224	Red Carrier (LHS) with bearing
BB01156	235.1156	Black Plastic Fingers
BB01158	235.1158	Red Fixed (RHS)
BB01157	235.1157	Red Fixed (LHS)
BB00322	031.0322	Nylock nut
BB09021	039.9021	Master Link

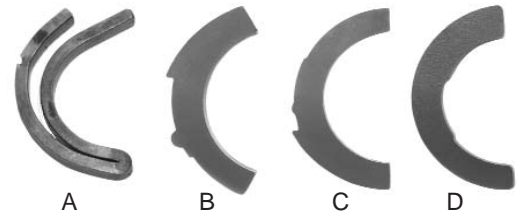

Gathering Chain Fingers

Part #	OEM #	Description
A	HS-353-B	Metal
B	FS14-356	Plastic hard or soft
C	VG25A201A	Plastic hard or soft
D	VG25A201	Plastic hard or soft

Gathering Chain



Muller* & Osako Gathering chain available. OEM quality pre-stretched

**CALL
for a
QUOTE**

Gathering Chain

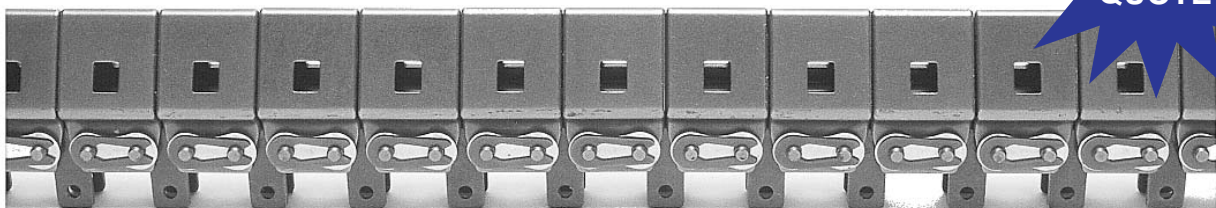

McCain, Harris-Macey and Sheridan*

*Brand names and trademarks published herein are registered trademarks of their respective companies. Birk & Blyme is not an authorised dealer for Muller, Heidelberg, Osako, Harris-Macey, Sheridan, McCain and Procetter products and do not offer genuine parts. Birk & Blyme supplies compatible high quality replacement parts



Parts for Harris* Macey* Heidelberg*

POCKETS - TRIMMER - COVERFEEDERS

Models 532, 542, 562, 650 & 705 (550 Trimmer)

Parts include, but are not limited to:

Cams	Bearings	Springs	Gears	Disc Valves
Shafts	Belts	Dipper Blades	Sucker Tubes	Rotary Valves
Grippers	Belt Pulleys	Bushings	Lever	Opener Pins
Gripper Seats	Sprockets	Segments	Lexan Guards	Pinion Gears

These parts are not manufactured by Heidelberg / Harris. They are made in the U.S.A to OEM standards.

Muller* Gathering Grippers

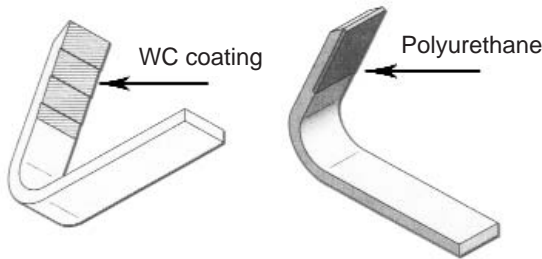

Part #	Mfg Ref #	Description
BB088-916	888.01115.3	WC coated gripper
BB088-925	888.01115.3mod	Polyurethane coated gripper

Muller* Belts



Part #	Mfg Ref #	Description
QMU0309	1528.1066.4	Cord 949.33 mm long
QMU0450	1528.1067.4	Belt
QMU0310	1528.1301.4	Cord 949.33 mm long
QMU0315	1529.1003.4	Round green belt
QMU0999	0016.0003	Rubber cord 5.0 mm diametre

Calendar Punch

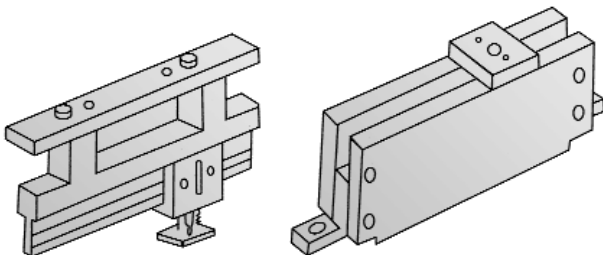

For Harris-Heidelberg Models 542, 550, 562, 650, 705 and 750

Eliminate the time consuming and tedious step of drilling your calendars.

With a 10 minute installation of the calendar punch, your stitcher-trimmer line can trim and punch in the same operation.

Specifications:

Maximum calendar size: 12" x 19 1/2"

Minimum calendar size: 3 1/2" x 8 1/2"

(comes with 3/16" or 1/4" punch set)

Centering Device

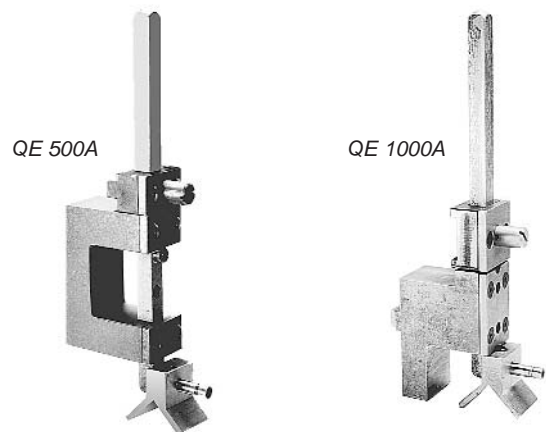

QE 500A

QE 1000A

Fits machines using 26D style stitching heads

Fits machines using 18D style stitching heads

*Brand names and trademarks published herein are registered trademarks of their respective companies. Birk & Blyme is not an authorised dealer for Muller, Heidelberg, Harris-Macey, Sheridan, and McCain products and do not offer genuine parts. Birk & Blyme supplies compatible high quality replacement parts



BB-0663

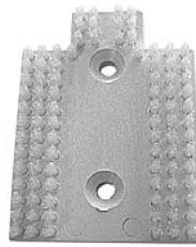

BB-0666

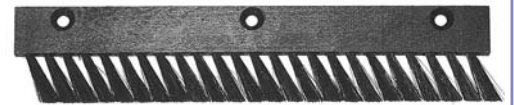

BB-0668



BB-0664



BB-0665



BB-0662

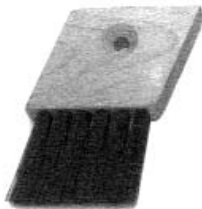

BB-0669



STL900-0768739



BB-0670



BB-0672 and BB-0673

Part #	Mfg Ref #	Description	Machine	Note
BB-0662	889.0726.4	Y-Brush wood block	Muller*	
BB-0663	890.1526.3	Brush	Muller*	
BB-0664	890.1527.3	Brass Brush	Muller*	
BB-0665	890.1007.3	Wood Block 13" x 3.68" x .312"	Muller*	
BB-0666	3670.2673.4	Pusher Brush 3670 Binder	Muller*	
BB-0667	3002.6783	Glue Pot Brush, Dia. 5-3/8" x 3.812"(L)	Muller*	not pictured
BB-0668	241.0915.3	Trimmer Brush	Muller*	
BB-0669	80118	Hold Down Brush 2" x 1.63" x .630"	Muller*	2 rows wide
BB-0670	360.3050.4	Trimmer Brush - Prima	Muller*	
BB-0671	360.3008.3	Prima Brush	Muller*	not pictured
BB-0672	220-098-01	Folder Brush - Right	Stahl*	
BB-0673	220-098-02	Folder Brush - Left	Stahl*	
BB-0674	12001143	(#03-1-558) PVC Block OD 8.5"	Kolbus*	not pictured
BB-0675	2391	(#03-1-559) PVC Block OD 3.5"	Kolbus*	not pictured
ST900-0768739	2141-269-BG-01	Brush strip 1103 mm long	Heidelberg ST300*	
Sbl-1075001	2142-469-01-00	ST300 Knock Up Brush	Heidelberg ST300*	not pictured

For brushes not listed above, please contact us for availability and/or submit your samples for quotation.

*Brand names and trademarks published herein are registered trademarks of their respective companies. Birk & Blyme is not an authorised dealer for Stahl, Muller, Kolbus, and Heidelberg products and do not offer genuine parts. Birk & Blyme supplies compatible high quality replacement parts



The prime source for all your sucker requirements...

Extensive range in Rubber, Vinyl, Urethane and Silicone for equipment such as:

Aster, Bourg, Duplo, Ferag, Harris Macey (Sheridan), McCain, Heidelberg/Stahl, Horizon, Muller Martini and Osako etc.

PLEASE SUBMIT YOUR SAMPLES!



692



520001245



520001168



6E8



6116



SM12B311



7200



95



9200



RVCB3



622 Green



23 Large



104



630B



630C

Reference #	Description	Use
692	Vinyl with cleats	Harris
520001245	White Rubber	Harris
52001168	White Rubber	Harris
6E8	White Rubber	Harris
6116	Blue Vinyl	Harris
SM12B311	Blue Vinyl	Harris
7200	Black Bellows	Harris/Sheridan
95		Harris/Sheridan
9200	Black Bellows	Heidelberg/Stahl McCain
RVCB3	Blue Vinyl	Heidelberg/Stahl McCain
622 Green	Green Vinyl	Heidelberg/Stahl
23 Large	Amber	Heidelberg/Stahl
104	Brown Bellows	Duplo/Horizon
630B	Blue Vinyl	Ferag
630C	Blue Vinyl	Ferag

Note

Please call us for Suckers not listed.

Extensive range available for most machines!

*Brand names and trademarks published herein are registered trademarks of their respective companies. Birk & Blyme is not an authorised dealer for Muller Martini, Ferag, Heidelberg, Harris, Duplo, Sheridan, Stahl and McCain products and do not offer genuine parts. Birk & Blyme supplies compatible high quality replacement parts

SUCKERS



020 1902



621Y



020 1909



020 1903



020 1901



020 1921



622 Clear



020 1910



020 T10



020 1923



020 T24



020 T14



020 1926



020 1927



020 1928

Reference #	Description	Note
020 1902	Blue Rubber	for light signatures
621Y	Yellow Vinyl	longer wearing than 020 1910 and 020 1923
020 1909	Black Rubber	Hard rubber. Less wear than 020 1903
020 1903	Orange Rubber	Normal capacity
020 1901	Red Rubber Cap	
020 1921	Black Rubber	Alt. to 020 1902
622 Clear	Clear Vinyl	longer wearing than 020 1903, -09, and -21
020 1910	Green Rubber	large suction capacity
020 T10	Black Rubber	Alternative to 020 1908
020 1923	Black Rubber	Replaces 020 1910
020 T24	Red Rubber Pad	
020 T14	Clear Vinyl	Replaces 345.3013.4
020 1926	<i>Aclathan</i> 5.0 mm	0370.427
020 1927	<i>Aclathan</i> 8.0	0370.569
020 1928	<i>Aclathan</i> 3.0 mm	0370.316
020 T20	Silicone Tube	9 x 6 x 1 mm

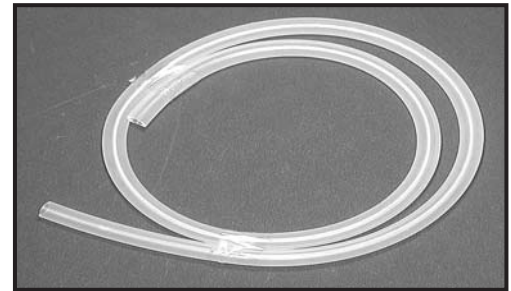

Silicone Tubing 020 T20

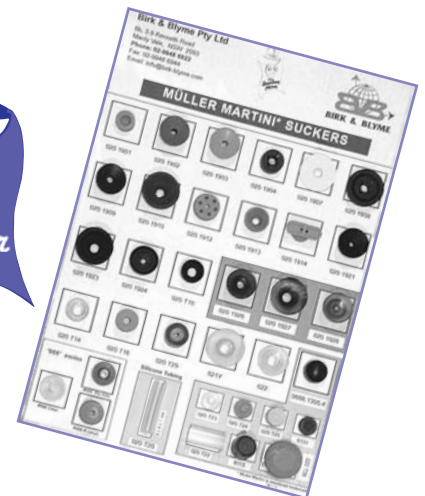

Please request our *Muller Sucker Chart for quick reference.

Partial list only! Please call for information on suckers and parts not listed above.

*Brand names and trademarks published herein are registered trademarks of their respective companies. Birk & Blyme is not an authorised dealer for Muller Martini, Ferag, Heidelberg, Harris, Duplo, Sheridan, Stahl and McCain products and do not offer genuine parts. Birk & Blyme supplies compatible high quality replacement parts

The cutting edge in quality





Paper Cutting Knives

Compare our quality and prices for value! We supply a range of high quality paper cutting knives imported from Germany's two leading knife manufacturers, Schönerberger and Fassco. Knives are available to suit both guillotines and three knife trimmers for all makes and models including: *Müller Martini, Polar, Sheridan, Wohlenberg, Harris Macey, Kolbus, McCain, Schneider, Heidelberg/Stahl, Osako and more!

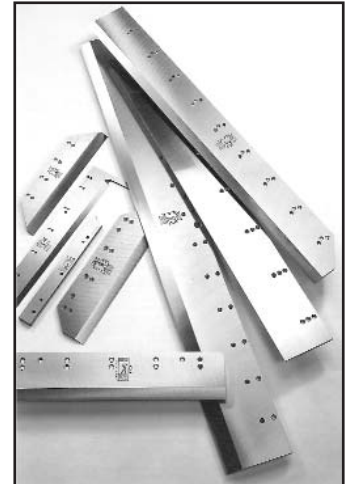
Steel Quality

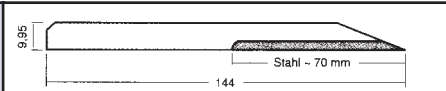
We offer the following selection of knife grades, so you can choose the right knife for your requirements.

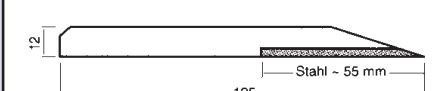
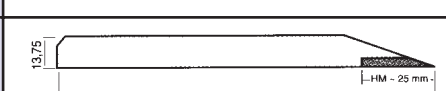

Quality	Code	Description	Info - Inserts
Standard Inlaid Tool Steel	F-220	The quality of the hardened cutting steel is well proven and suitable for universal use.	
High Carbon/High Chrome (12% Chromium)	F-236	Widely used for lower knives in three knife trimmers. Out performs standard steel 2:1	 For shear cut type applications only.
High Speed Steel (HSS) (18% Tungsten inlay)	F-3000	Designed to be more abrasion resistant. This knife will reduce down-time with approx 3-5 times longer life than F-220	
TCT Tungsten Carbide Tipped	TCT	Well known quality with high wear resistance. Out performs F-3000 up to 3 times.	
LONG LIFE Super Fine Grain Tungsten	LL	For applications where knife changes must be avoided as long as possible. Approximately 2 times longer life than standard TCT knives.	 Super Fine Grain
MEGA LIFE Super-Micro-Fine Grain Tungsten	ML	Improved cutting quality with less dust. Reduced tendency of cutting edge breaking.	Approx 3-4 times longer life than standard TCT knives.

*Müller Martini Knife Set for 890, IGV, 217, 221, 335, 1509

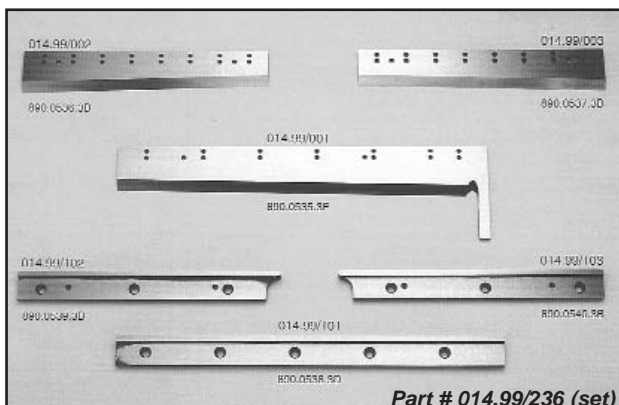









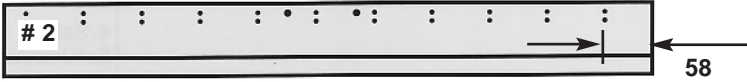

Schönerberger WIDIA
Tungsten Carbide, LONG and MEGA LIFE manufacturer

FASSCO
REMSCHIED
Standard, High Chrome and High Speed Steels manufacturer

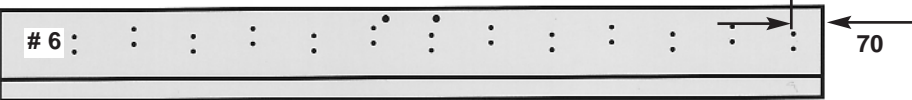
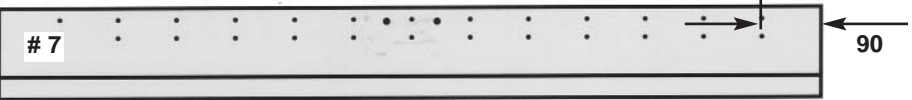
Large inventory of both Standard Trimmer and Punch Cut knives, available for **SAME DAY/NEXT DAY DELIVERY.**

*Brand names and trademarks published herein are registered trademarks of their respective companies. Birk & Blyme is not an authorised dealer for Muller Martini, Polar, Wohlenberg, Heidelberg, Harris, Osako, Wohlenberg and Kolbus products and do not offer genuine parts. Birk & Blyme supplies compatible high quality replacement parts

Hole Configuration - POLAR 92, 115 & 137 Guillotine Knives

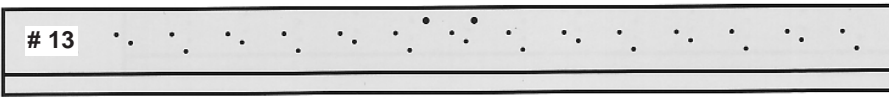
Blade hole pattern	Fits model	In steel quality
	Polar 92 EL/EM/EMC/CE # 007.26	F-220, F-3000
	Polar 92 EM/EMC/SD/MON # 007.34	F-220, F-3000
	Polar 92 S/E/ED # 007.40	F-220, F-3000
	Polar 92 EL/EM/EMC/CE # 007.26/TCT	Tungsten Carbide Tipped (TCT)
	Polar 92 EM/EMC/SD/MON & S/E/ED # 007.34/TCT, 007.40/TCT	Tungsten Carbide Tipped (TCT)
	Polar 115 EL/CE/EMC # 007.24	F-220, F-3000
	Polar 115 NMW/X/XT # 007.31	F-220, F-3000
	Polar 115 S/E/ED # 007.41	F-220, F-3000
	Polar 115 <i>Fits all the above 115 models</i>	Tungsten Carbide Tipped (TCT)
	Polar 137 EL/EMC # 007.27	F-220, F-3000
	Polar 137 NMW/X/XT # 007.32	F-220, F-3000
	Polar 137 S/E/ED # 007.42	F-220, F-3000
	Polar 137 <i>Fits all the above 137 models</i>	Tungsten Carbide Tipped (TCT)

Please call us for further information on the above, and/or other models not listed.

*Brand names and trademarks published herein are registered trademarks of their respective companies.

Birk & Blyme is not an authorised dealer for Polar products and do not offer genuine parts. Birk & Blyme supplies compatible high quality replacement parts

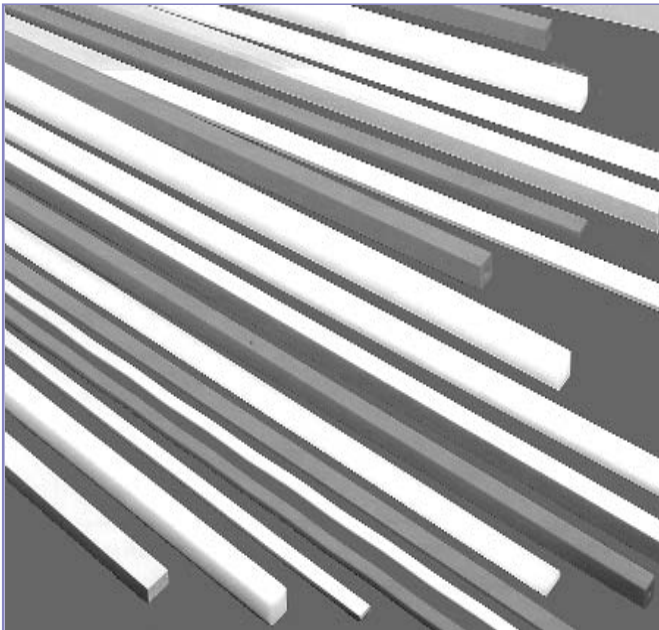

Cutting Sticks

Our premium quality imported cutting sticks will extend knife life and reduce machine downtime. **Do NOT compromise your knives with poor quality cutting sticks.**

Range

- For all paper cutters and three knife trimmers
- All sizes and material

Availability

- Cuttings sticks are available for most Guillotines and Trimmers including: *Polar, Wohlenberg, Itoh, Ideal, Horizon, Schneider, Sheridan, Müller Martini, Kolbus, Perfecta and many more.

Material	Colour	Quality	Hardness Shore "D"	Application
uPVC	Red	Standard	80-82	Standard Steel Knives
HDPE	White or Green	Economy	67-68	All Knives except Trimmers
Polypropylene	Beige, Grey or Pink	Enviromental	72-75	TCT & Trimmer Knives
Nylon	White	Premium	80-83	HSS & TCT Trimmer Knives

Commonly stocked sizes

Part #	Fits machine	Colour / type	Length	Square
CS-POL-92R	Polar 92, Perfecta	Red wavy	930	10 x 4.5 mm
CS-POL-92G	Polar 92, Perfecta	Grey wavy	930	10 x 4.5 mm
CS-POL-115R	Polar 115, Perfecta	Red wavy	1160	10 x 4.5 mm
CS-POL-115G	Polar 115, Perfecta	Grey wavy	1160	10 x 4.5 mm
CS-POL-137R	Polar 137, Perfecta	Red wavy	1380	10 x 4.5 mm
CS-POL-137G	Polar 137, Perfecta	Grey wavy	1380	10 x 4.5 mm
CS-WOL-92R	Wohlenberg 92, Schneider	Red wavy	930	10 x 4 mm
CS-WOL-92G	Wohlenberg 92, Schneider	Grey wavy	930	10 x 4 mm
CS-WOL-115R	Wohlenberg 115, Schneider	Red wavy	1159	10 x 4 mm
CS-WOL-115G	Wohlenberg 115, Schneider	Grey wavy	1159	10 x 4 mm
CS-WOL-137R	Wohlenberg 137, Schneider	Red wavy	1380	10 x 4 mm
CS-WOL-137G	Wohlenberg 137, Schneider	Grey wavy	1380	10 x 4 mm
CS-ITOH-1193R	Itoh 115	Red straight	1193	15.9 x 15.9 mm
CS-IDEAL-570	Ideal 4700 / 4810 / 4850	Red straight	570	14 x 14 mm
CS-IDEAL-885	Ideal 7228	Red straight	885	14 x 14 mm
CS-298-WHITE	Horizon HT 70	White	298	15 x 7 mm
CS-335-WHITE	Horizon HT 70	White	335	12 x 12 mm
CS-1000-WHITE	Muller Martini, Kolbus	White straight	1000	10 x 10 mm
CS-1000-GREY	Muller Martini, Kolbus	Grey straight	1000	10 x 10 mm
CS-1050-GREY	Wohlenberg	Grey straight	1050	24 x 4 mm

All other sizes available on request!



*Brand names and trademarks published herein are registered trademarks of their respective companies. Birk & Blyme is not an authorised dealer for Muller Martini, Polar, Wohlenberg, Heidelberg, Harris, Osako, Wohlenberg and Kolbus products and do not offer genuine parts. Birk & Blyme supplies compatible high quality replacement parts

Knife Guards

For 3 Knife Trimmers & Guillotines



- Great protection while transporting knives.
- Adds protection while servicing machine.
- Magnetic strip holds guard firmly in place
- All plastic construction from yellow uPVC

Mag Pads



For just a few dollars you can put the Mag Pad to work protecting your delicate papers stocks from cutter clamp marks and damage. The durable magnetic rubber surface on one side holds the pad securely in position on the clamp while cutting. The high density foam pad prevents sharp edges of the clamp fingers from marking stock.

Pack includes two (2) 3" x 15" pads.

Custom sizes available on request.

Book Hold Down/Guides

47 C-Shape

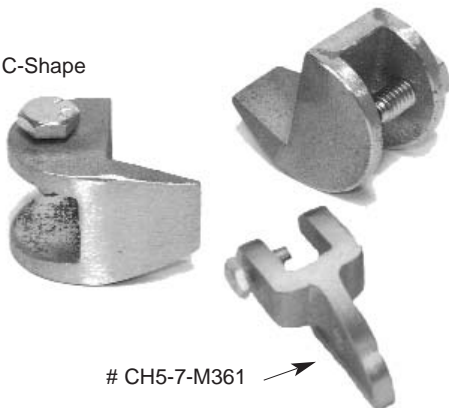

CH5-7-M361 →

Book Guides is an essential tool to assure an even cut when trimming books on a guillotine. Attaches to the back gauge and compress the spine of the books to assure a quality cut.

Jogger Blocks

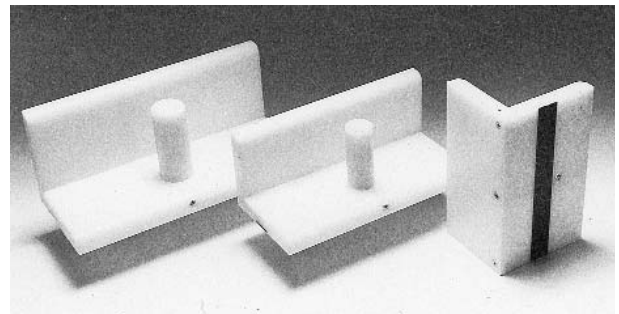

Jogger Blocks, heavy duty plastic with magnetic strip on base helps jog bottom sheets perfectly.

Angle Guides

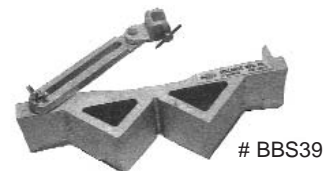

BBS39

Angle Guides for printers that need to cut corners, this is the right little tool.

- Cuts on any angle from 0-170°
- Slides and locks onto back gauge
- Cuts corners, tags and shapes

*Brand names and trademarks published herein are registered trademarks of their respective companies.

Müller Martini* & Kolbus* Milling Heads & Saw Blades



Part #	OEM #	Description	Notes
60035	0896.1130.2	Milling Head 235x 70x 17	12 Teeth
60019	3000.4440.2	Equaliser Blade 200x120x32.5	45 Teeth
60039	3000.5516.2	Milling Head 250x 80x 37, Normbinder	30 Teeth
60041	3002.8312.1	Milling Head 320x 80x 37, Corona	30 Teeth
60042	3002.8729.1	Milling Head 320x 80x 37, Corona	45 Teeth
60045	3009.2568.1	Milling Head 320x 40x 35, Trendbdr	30 Teeth
60273	3009.5053.2A	Saw Blade 220 x 188 x 19	48 Teeth
60038	3010.2154.1C	Milling Head, LEFT 250x80x37	27 Teeth
60040	3010.2155.1C	Milling Head, RIGHT 250x80x37	27 Teeth
60097	3601.1234.3A	Saw Blade, Carbide	
60098	3501.1235.3A	Saw Blade, Carbide 400x 35x 1.8	108 Teeth
60100	3501.1236.3A	Saw Blade, Carbide 400x 35x 2.8	108 Teeth
60099	3501.1238.3A	Saw Blade, Carbide	
91019	1244.47.066.00	Milling Head 300 x 80 x 37/32, 30T	Kolbus*

Milling, Roughing & Carbide Inserts

Part #	OEM #	Description	Notes
60027	0209.0572.4	Milling Knife 88 x 16 x 16	
60002	0209.0603.4	Roughing Knife 36 x 19 x 9	p.0896.1139
60096	0251.2016.4	Knife 26 x 22 x 16	
60031	0896.1108.4	Milling Knife, 75 x 20 x 20	PONY RB
60006	0896.1112.4	Roughing Knife, 36 x 16 x 9	PONY RB
60014	0896.2816.4	Grinding Wheel, 100 x 10 x 21	Diamond
60005	1530.3012.3	Roughing Knife 59 X 20 X 20	PANDA
60281	1530.3051.4	Roughing Knife 35 X 18 X 1 (plain)	p.3001.8931.4
60028	1580.1480.3	Milling Knife 66 x 20 x 20	
60271	1580.2146.4	Milling Knife 75 x 20 x 20	
60034	3000.5473.4	Milling Knife 63x 20x 20, Star/Nrmbdr	p.1530.2948.3
60032	3009.5553.3	Milling Knife 64.3x 18x 18, Trendbind.	
60059	3009.6987.4	Carbide Insert 13.5 x 6 x 3	
60003	3010.2824.4	Roughing Blade, 35x 18x 1, Corona	26 Teeth
60287	3011.2078.4	Carbide Insert 20.25 x 13.78 x 2	3011.2629.4
60009	3050.8950.4	Roughing Knife, Carbide 1.0 mm	30 Teeth
60007	3050.8950.5-1.5	Roughing Knife, Carbide 1.5 mm	30 Teeth
60008	3050.8950.5/1	Roughing Knife, Carbide 1.75 mm	30 Teeth
60029	3050.9840.4	Milling Knife 41 x 18 x 5	
60033	3061.1077.3	Milling Knife, 23 x 10 x 10.6	ECONO
60004	3061.1079.3	Roughing Knife, 23 x 10 x 10.6	ECONO
BB-0062	49-7-382	Milling Knife, Carbide	KOLBUS*

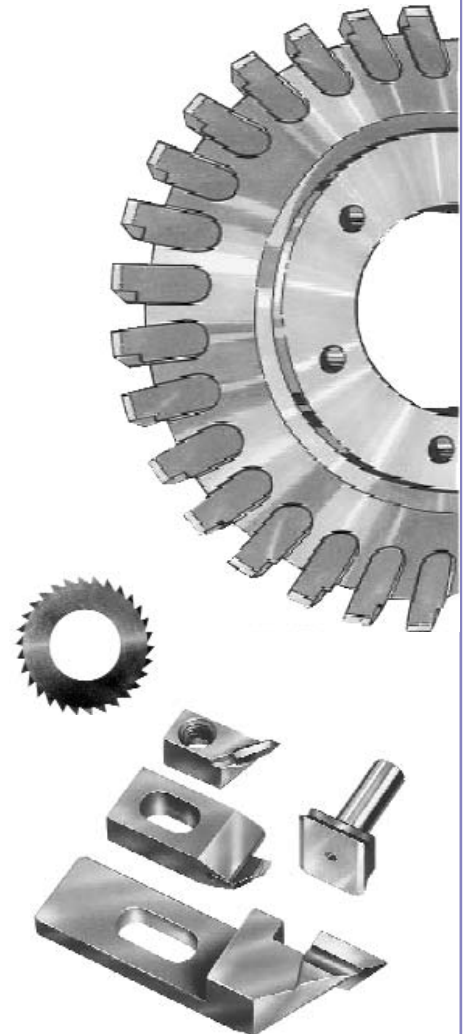

*Brand names and trademarks published herein are registered trademarks of their respective companies.

Birk & Blyme is not an authorised dealer for Muller Martini and Kolbus products and do not offer genuine parts. Birk & Blyme supplies compatible high quality replacement parts

Single Stream Rotary Trimmers - Müller*

Part #	Reference	Description
60058	0341.3320.4	Carbide Insert 19.05 x 19.05 x 4.76
60024	0341.3322.4	Knife, LEFT + RIGHT 55 x 14 x 5.8
60079	0341.3325.2	Knife Holder, L + R 250 x 70 x 34 - 24 teeth
60215	0341.3330.2	Knife (anvil) Bottom 148 x 100 x 10
60225	0341.3393.3	Knife, Bottom Steel 120.5 x 40 x 10
60021	0341.3397.4	Knife, LEFT 60 x 18 x 5
60026	0341.3398.4	Knife, RIGHT 60 x 18 x 5
60076	0341.3399.2	Knife Holder, LEFT 250 x 70 x 39 - 18 teeth
60084	0341.3400.2	Knife Holder, RIGHT 250 x 70 x 39 - 18 teeth
60204	0341.3442.3	Knife, Bottom Carbide 120.5 x 40 x 10
60001	0341.3513.4	Wetstone 150 x 50 x 17
60201	0441.1417.3	Knife, Bottom Carbide 155.2 x 25 x 15
60294	0441.1433.3	Knife, Bottom Carbide 155.2 x 25 x 9
60230	0441.1428.3	Knife, Bottom VANADIS10 156x 25x 15
60022	0441.1454.4	Knife, LEFT 65 x 18 x 5 (p.0441.1412.4)
60025	0441.1455.4	Knife, RIGHT 65 x 18 x 5 (p.0441.1414.4)
60084	0441.1456.2	Knife Holder, LH 250x 70x 39.3, 18T (p.0441.1411.2)
60085	0441.1457.2	Knife Holder, RH 250x 70x 39.3, 18T (p.0441.1413.2)
60015	0441.2518.4	Grinding Wheel, Diamond 100x 10x 36 (p.0311.1235.4)

Inline rotary cutters are made by **Schönenberger WIDIA^W** to suit the following machines

Gämmerler
Rota-Schneider
Rima
Müller Martini
Custom Bilt®
Rock Bilt

Other makes available on request!

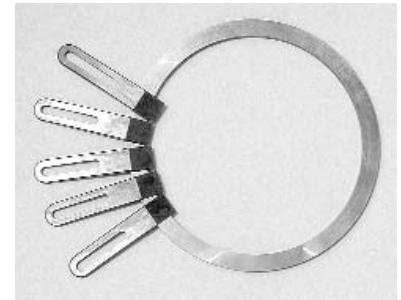

Schönenberger style rotary cutter with **MEGA LIFE** inserts for Gämmerler Trimmers.

*Gämmerler, Kolbus & Rota-Schneider Blades

Ref Number	Description	Notes
G-250-Sch	Slitter Ø250 mm	Gämmerler
G-200-Sch	Slitter Ø200 mm	Gämmerler
G-Anvil/Bsc	Anvil, Carbide Ø154 mm	Gämmerler
G-Anvil/Ssc	Anvil, Carbide Ø120 mm	Gämmerler
G-Sgmnt	Knife Segment 72 x 14 x 4	Gämmerler
G-Sgmnt2	Knife Segment, Tapered, Short	Gämmerler
01613012A	Upper Knife, ASP 23 HSS, Ø305 mm	RS / RIMA
011612006	Lower Kife, ASP 23 HSS, Ø300 mm	RS / RIMA
387 68 011	Upper Knife, LEFT Carbide 60 Serrations	RS / RIMA
387 68 012	Upper Knife,RIGHT Carbide 60 Serrations	RS / RIMA
E-055-09-850	Anvil, Carbide 150 x 110 x 6mm	RS / RIMA
BB-0407	Knife Segment 50 X 14 X 4 mm	RS / RIMA
10-3-114-TW	Rotary Knife 156 x 105 x 7 mm	Kolbus
10-3-113-TW	Rotary Knife 165 x 105 x 7 mm	Kolbus

*Gämmerler Cutters in Schönenberger design

The Newly Designed **Schönenberger** Rotary Milling Cutters to suit *Gämmerler machines are fitted with **MEGA LIFE** Carbide inserts, not standard Carbide! Will last 2-3 times longer than standard Carbide. Call for more information!

Ref Number	Description	Notes
BB92015 & 92016	Complete Milling Head 200 Dia. (L & R)	20 teeth
BB92022 & 92023	Complete Milling Head 250 Dia. (L & R)	26 teeth
BB92029 & 92030	Complete Milling Head 320 Dia. (L & R)	30 teeth
92036	MEGA LIFE insert 55 x 18 x 5 mm, L	200 Dia. Head
92037	MEGA LIFE insert 55 x 18 x 5 mm, R	200 Dia. Head
92018	MEGA LIFE insert 55 x 18 x 5 mm, L	250/320 Dia. Hd
92019	MEGA LIFE insert 55 x 18 x 5 mm, R	250/320 Dia. Hd

*Brand names and trademarks published herein are registered trademarks of their respective companies. Birk & Blyme is not an authorised dealer for Gämmerler, RIMA, Muller Martini, Rota-Schneider, Custom Bilt and Rock Bilt products and do not offer genuine parts. Birk & Blyme supplies compatible high quality replacement parts



Paper Drills, Baseboards and sharpening tools to suit Lihit, Sterling, Uchida, Iram, Citoborma, Hang etc.

Teflon Coated drills available in many sizes. Provide lubricity to the inside and outside of your drills. Slugs flow smoothly without binding. Friction is reduced to increase the wear life of the cutting edge. This is a very good coating for keeping slugs from building up and breaking the drills. Works better on varnished or laminated stock.

D1



Uchida VS10 & VS15

Head Dia. 11 mm - Overall Length 65 mm

Hole Size	Drilling Capacity	Part #
3.0 mm	30 mm	D1-3-30
4.0 mm	30 mm	D1-4-30
5.0 mm	30 mm	D1-5-30
6.0 mm	30 mm	D1-6-30
Baseboards, pack of 5		
All metal sharpening tool		
Sharpening kit (Stone/Sharp. tool)		

D3



Uchida VS25, VS55 & VS200, Citoborma, Stago, Hang, Corta etc.

Head Dia. 11 mm - Overall Length 65 mm

Hole Size	Drilling Capacity	Part #
3.0 mm	30 mm	D3-3-30
4.0 mm	40 mm	D3-4-40
5.0 mm	50 mm	D3-5-50
5.5 mm	50 mm	D3-5.5-50
6.0 mm	50 mm	D3-6-50
As above - *Teflon Coated		
6.5 mm	50 mm	D3-6.5-50
7.0 mm	50 mm	D3-7-50
8.0 mm	50 mm	D3-8-50
9.0 mm	50 mm	D3-9-50
Baseboards for VC25, pack of 5		
Baseboards for VS55, pack of 5		
All metal sharpening tool		
Sharpening kit (Stone/Sharp. tool)		

D2



Uchida VS25, VS55 & VS200, Citoborma, Stago, Hang, Corta etc.

Head Dia. 16 mm - Overall Length 65 mm

Hole Size	Drilling Capacity	Part #
10.0 mm	50 mm	D2-10-50
11.0 mm	50 mm	D2-11-50
12.0 mm	50 mm	D2-12-50
13.0mm	50 mm	D2-13-50
All metal sharpening tool, for large sizes		

D4



Lihit 2001

Head Conical- Overall Length 53 mm

Hole Size	Drilling Capacity	Part #
4.0 mm	26 mm	D4-4-26
5.0 mm	26 mm	D4-5-26
6.0 mm	26 mm	D4-6-26
6.5 mm	26 mm	D4-6.5-26
Baseboards, pack of 5		
All metal sharpening tool		
Sharpening kit (Stone/Sharp. tool)		

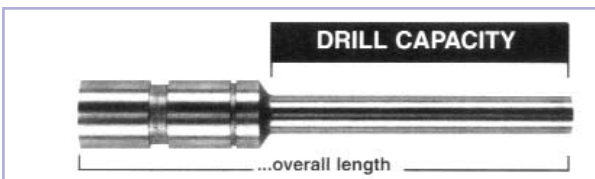

*Brand names and trademarks published herein are registered trademarks of their respective companies. Birk & Blyme is not an authorised dealer for Lihit, Iram, Citoborma, Hang, Corta, Sterling and Uchida products and do not offer genuine parts. Birk & Blyme supplies compatible high quality replacement parts

D5



Lihit 2003

Head Conical- Overall Length 60 mm

Hole Size	Drilling Capacity	Part #
6.5 mm	32 mm	D5-6.5-32
Baseboards, pack of 5		
All metal sharpening tool		
Sharpening kit (Stone/Sharp. tool)		

D7



Sterling, Custom, PDC, Kuhl etc.
Scew in type head

Hole Size	Drilling Capacity	Part #
1/8"	20 mm	D7-1/8-20
5/32"	25 mm	D7-5/32-25
3/16"	30 mm	D7-3/16-30
7/32"	35 mm	D7-7/32-35
1/4"	50 mm	D7-1/4-50
9/32"	50 mm	D7-9/32-50
5/16"	50 mm	D7-5/16-50
3/8"	50 mm	D7-3/8-50
7/16"	50 mm	D7-7/16-50
Baseboard 753 x 24.4 x 4.5 mm		
All metal sharpening tool complete		
Replacement three flute sharpening bit		

D6



Lihit 1013 & 1015

Head Conical - Overall Length 80 mm

Hole Size	Drilling Capacity	Part #
3.0 mm	25 mm	D6-3-25
4.0 mm	45 mm	D6-4-45
5.0 mm	45 mm	D6-5-45
6.0 mm	45 mm	D6-6-45
6.5 mm	45 mm	D6-6.5-45
7.0 mm	45 mm	D6-7-45
8.0 mm	45 mm	D6-8-45
Baseboards for DS-VC25, pack of 5		
Baseboards for VS55, pack of 5		
All metal sharpening tool		
Sharpening kit (Stone/Sharp. tool)		

D8



Iram, Citoborma, Hang, Nagel, Corta etc.

Head Dia. 11 mm - Overall Length 100 mm
**Overall Length 86 mm*

Hole Size	Drilling Capacity	Part #
*3.0 mm	30 mm	D8-3-30
4.0 mm	40 mm	D8-4-40
5.0 mm	65 mm	D8-5-65
6.0 mm	65 mm	D8-6-65
As above - *Teflon Coated		
7.0 mm	65 mm	D8-7-65
8.0 mm	65 mm	D8-8-65
9.0 mm	65 mm	D8-9-65
10.0 mm	65 mm	D8-10-65

HOW TO ORDER













Example: Lihit Drill, 6.5 mm hole

Part Number: D6-6.5-45



Order online at
www.order.birk-blyme.com

DRILL DIAMETRES CONVERSION TABLE

						
1/8" (3mm)	5/32" (4mm)	3/16" (4.7mm)	7/32" (5.4mm)	1/4" (6.4mm)	9/32" (7mm)	5/16" (8mm)
						
11/32" (8.7mm)	3/8" (9mm)	13/32" (10.3mm)	7/16" (11mm)	1/2" (12.3mm)	9/16" (14mm)	

*Brand names and trademarks published herein are registered trademarks of their respective companies. Birk & Blyme is not an authorised dealer for Lihit, Iram, Citoborma, Hang, Corta, Sterling and Uchida products and do not offer genuine parts. Birk & Blyme supplies compatible high quality replacement parts

Drill Heads

Lawson* Style Drillhead

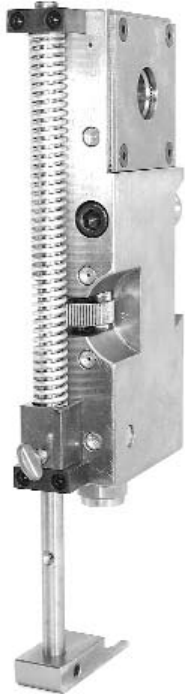

Challenge* Style Drillhead



Nygren Dahly* Style Drillhead



Paper Drill Sharpeners

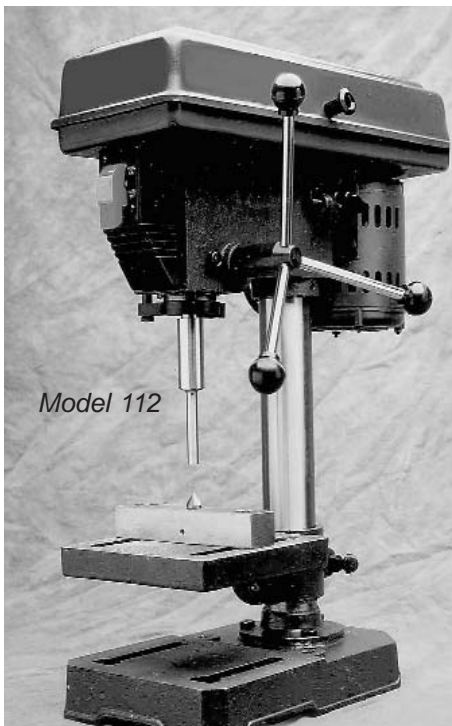

Will sharpen Nygren, Lawson, Challenge and more.

Includes entire drill press with reaming fixture and accessories for sharpening most paper drills.

Call for quotation

Model # 112

Hand Held tools

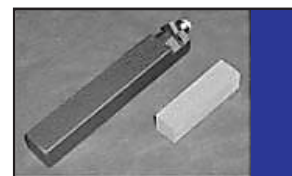

Sharpening Tool
(D1, D2, D4, D5, D6 Drill Bits)
SHP-AM-01



Sharpening Tool
(for Sterling D7 Drill Bits Only)
SHP-STL-01

*Brand names and trademarks published herein are registered trademarks of their respective companies. Birk & Blyme is not an authorised dealer for Lawson, Challenge and Nygren Dahly and do not offer genuine parts. Birk & Blyme supplies compatible high quality replacement parts

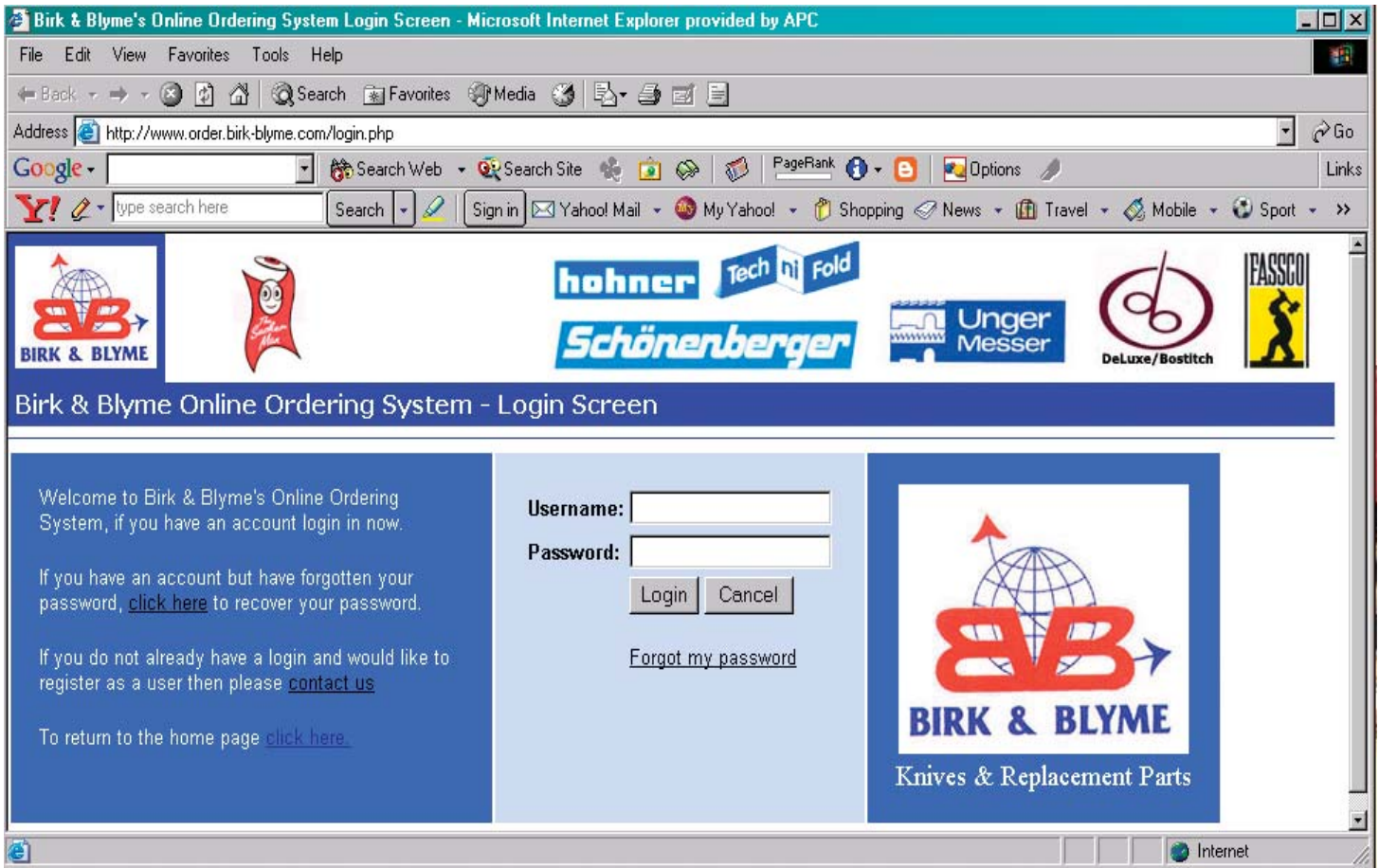

ONLINE ORDERING

It's simple, just call or email us and we will organise a Username and Password.*

IT'S QUICK & EASY!

Go to www.order.birk-blyme.com.

Type in your secure username and password, you can then begin to browse our catalogue of products. You decide which product and quantity, the ordering form lists your order and calculates the costs, you simply hit okay and the order is emailed. The order is processed and delivered ASAP.

* To approved applicants.

- **Extensive listings of products**
- **Search functions, by**
Part Number
Product Name
or OEM Number (where possible)
- **Current pricing and availability**
- **Check your order history**
- **Track your order**
You can find out at what stage your order is at i.e; being processed/shipped from warehouse or on back order.



DRILLING



SUCKERS



STITCHER PARTS



CUTTING

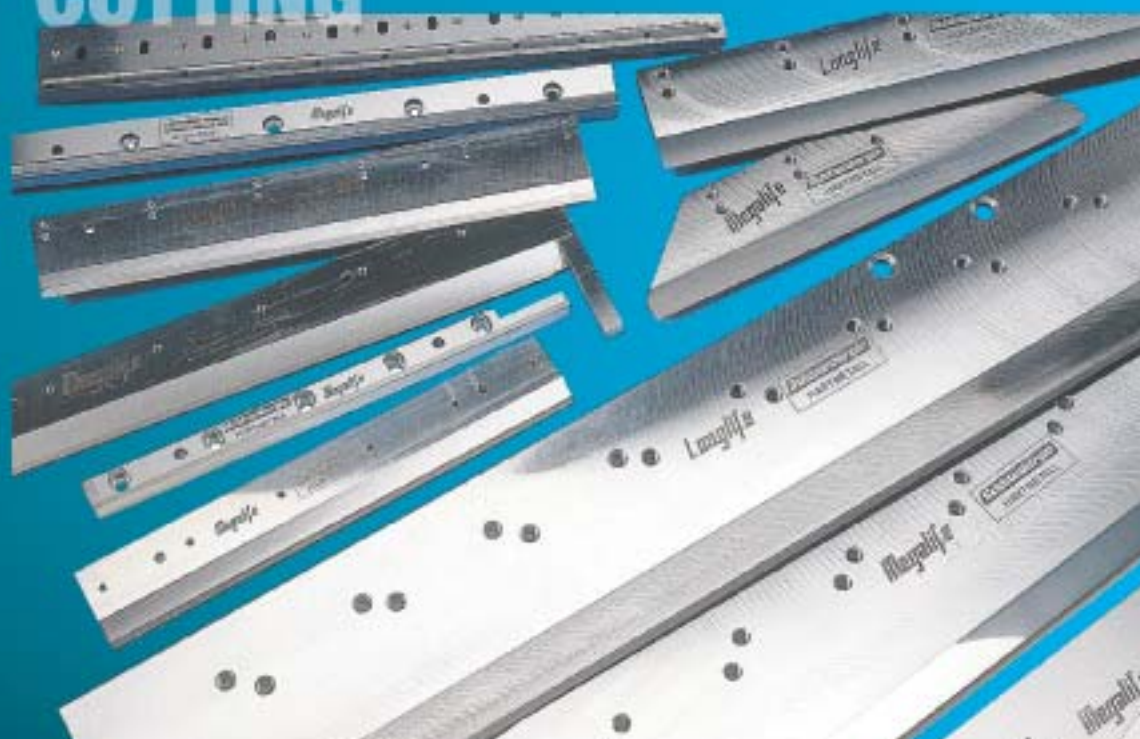

BIRK & BLYME

6B, 3-9 Kenneth Road,
Manly Vale, NSW 2093
Australia

Tel: 61 2 9948 6822

Fax: 61 2 9948 6944

Email: info@birk-blyme.com

www.birk-blyme.com